

# VECTOR

**V08 ENT M75**

**V08 ENT M11**

**V08 ENT M12**

V 8 MODEL  
DIESEL CYCLE  
FOR MARINE APPLICATIONS

## INSTALLATION DIRECTIVE

MAY 2006 EDITION

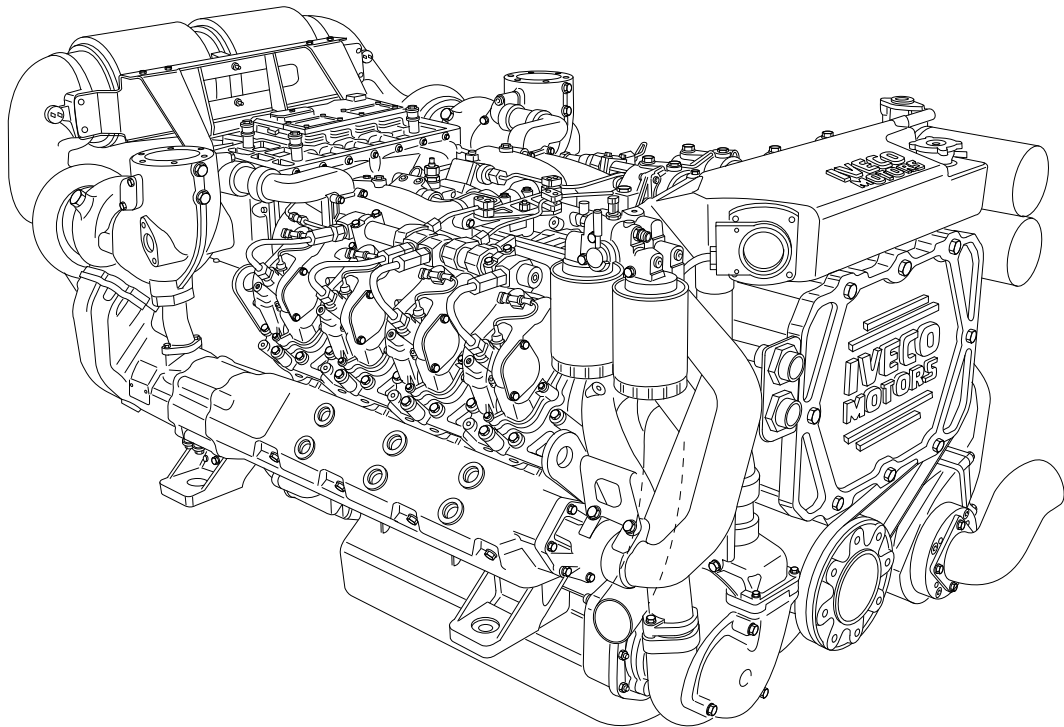

**IVECO  
MOTORS**

**FPT**  
POWERTRAIN TECHNOLOGIES

## FOREWORD

We strongly recommend that you carefully read the indications contained in this document: compliance with them protects the engine against irregular operation and assures its reliability, safeguarding sea-going and maintenance personnel against accident hazards.

The indications contained in this directive pertain to the V08 ENT M75 - M11 - M12 engines and complement the IVECO MOTORS publication "Guide to the Installation of Marine Engines", the reader should refer to for anything that is not explained herein.

For more complete information about the engine, please refer to the appropriate technical brochure.

Use of fuels and oils with different characteristics from those set out in the operation and maintenance manual may compromise the regular operation of the engine, limiting its performance, reliability and working life.

Exclusive use of IVECO Original Parts is a necessary condition to maintain the engine in its original integrity.

Tampering, making modifications and using non original parts can jeopardize the safety of boat engineers and users.

### To obtain spare parts, you must indicate:

- Commercial code, serial number and indications shown on the engine tag;
- Part number of the spare as per spare part catalog.

The information provided below refer to engine characteristics that are current as of the publication date. IVECO MOTORS reserves the right to make modifications at any time and without advance notice, to meet technical or commercial requirements or to comply with local legal and regulatory requirements.

### We refuse all liability for any errors and omissions.

The reader is reminded that the IVECO MOTORS Technical Assistance Network is always at the Customer's side with its competence and professionalism.

Publication IVECO MOTORS edited by:  
IVECO PowerTrain  
Advertising & Promotion  
Pregnana Milanese (MI)  
[www.ivecomotors.com](http://www.ivecomotors.com)

Printed **P3D64V001 E** - May 2006 Edition

## CONTENTS

	Page
1. WARNINGS AND CAUTIONS	4
2. ENGINE PARTS AND COMPONENTS	6
3. INSTALLATION OVERVIEW	10
4. GENERAL INSTALLATION CRITERIA	11
5. TECHNICAL DATA FOR INSTALLATION	<b>12</b>
6. IDENTIFICATION DATA	14
7. FUEL LINE	15
8. ELECTRICAL EQUIPMENT	17
9. MAIN ANALOG INSTRUMENT PANEL	26
10. SECONDARY ANALOG INSTRUMENT PANEL	30
11. DRILLING PLANS FOR ANALOG PANELS	31
12. CUSTOMIZED INSTRUMENT PANEL	32
13. SENSORS FOR DETECTION AND INSTRUMENT PANEL SIGNALLING	34
14. PREPARING THE ENGINE FOR FIRST START-UP	37
15. TESTS BEFORE THE FIRST START-UP	37
16. FIRST ENGINE START	38
17. EDC ECU INDICATION LIGHTS	40
18. UNDERWAY CHECKS	43
19. PREPARING THE ENGINE FOR LONG IDLE PERIODS	44
20. ELECTRIC DIAGRAMS	46
21. APPENDIX	53

### Indications for consultation

The different versions of the motors are generally shown using the same pictures and descriptions, however important differences are shown separately.

## 1. WARNINGS AND CAUTIONS

To obtain the best engine performance, it is essential not to deviate from the mission profile for which it was produced and set up. The engine must not be used for purposes other than those stated by the manufacturer. IVECO MOTORS is willing to examine any need for particular installations beforehand. Use of an electronically controlled injection system, in providing the engine with performance benefits, requires that the installer and maintenance specialist comply with some fundamental rules, which will become more and more commonplace as use of such equipment becomes progressively more widespread. Boat outfitters and maintenance specialists are invited to closely follow the instructions contained herein. No modifications to the engine, its accessories and components, are allowed.

**Failure to comply with the instructions that follow shall void the warranty and relieve IVECO MOTORS of all liabilities.**

### For personnel safety

Specialists and installers are cautioned to comply with workplace safety rules and to adopt prescribed individual protection devices when working.

- ❑ Drain the cooling, lubrication and fuel lines only after the fluids have duly cooled. The pressurized cap of the coolant line may be opened only after the engine has duly cooled.
- ❑ Batteries contain a highly corrosive sulphuric acid solution: must never be upset and must be handled with the utmost caution to prevent spillage. Ensure that the battery compartment is adequately ventilated.

### Handling

The engine must be handled by experienced personnel, using the prescribed tool or a rocker arm that keeps the lifting lines parallel and with adequate equipment in terms of capacity and size. The two eyebolts provided for lifting the engine alone must always be used simultaneously.

### Installation

- ❑ Knife switches or battery breakers may be used on the power supply line of the engine electronic unit, provided they are not used to shut off the engine.
- ❑ Do not modify the wiring harnesses; their length may not be modified: use only available extensions.
- ❑ Do not use electronic device wiring harnesses not compliant with the IVECO MOTORS directive, in terms of length, type of conductor, location, clamping, connection of the shielding and earth braids.
- ❑ To avoid any interference, the wiring harnesses of the different on-board electronic devices must follow different paths from those of the engine electronic systems.

- ❑ Do not connect any extraneous user device to the engine electrical equipment.
- ❑ Do not energize the on-board electrical system of the boat without first verifying that there are no short circuits.
- ❑ Do not branch pipes off to draw fuel from the engine supply lines.
- ❑ Do not make any change to the engine's hydraulic circuits and components.
- ❑ Do not execute arc welding operations before removing the electronic units from their seating, placing them at an adequate safety distance.
- ❑ Do not subject electronic units to temperatures exceeding 80°C.
- ❑ Do not paint electrical components and their connections.
- ❑ Do not alter the data contained in the engine control electronic unit.
- ❑ Comply with prescribed procedures and torque values when tightening threaded elements.

### Start-up

- ❑ Ready the engine following the procedure set out in Chapter 14.
- ❑ When starting the engine the first time, have suitable means available to cut off air intake in case of a runaway condition.
- ❑ Start the engine after ensuring that it is complete with every part specified by the manufacturer and required by the installation, without attempting to start it with caps and occlusions to the lubrication, cooling and fuel feed lines.
- ❑ Check that the fluid lines are perfectly sealed, especially lines for fuels and lubricants, which may cause fires and consequent harm to persons and equipment.
- ❑ Make sure that the various pipelines are not in contact with warm surfaces or moving parts.
- ❑ The installing yard is required to carry out tests to verify the functional compatibility between the electrical-electronic equipment of the engine and the other electronic equipment present on the boat.

### Tests and tuning up

- ❑ Never disconnect the batteries when the engine is running.
- ❑ Remove the electrical connections from the batteries before any operation on the electrical system.
- ❑ Ensure that the battery terminals comply with the exact polarity, are properly tightened and protected against accidental short circuits and corrosion phenomena.

- Do not connect or disconnect electrical connections when electrical power supply is on.
- Do not cause sparks in the attempt to verify the presence of electrical voltage.
- Do not draw fuel through unfiltered lines.
- Do not clean the engine and its parts with corrosive or abrasive detergent substances, to avoid compromising the integrity of electrical connections.
- The engine fluids and air, coolant, and oil filters discarded after use must be properly stored and delivered to appropriate collection centres.

### **Long engine inactivity periods**

Before long periods of inactivity, ready the engine following the procedure set out in Chapter 19.

## 2. ENGINE PARTS AND COMPONENTS

Figure 1A

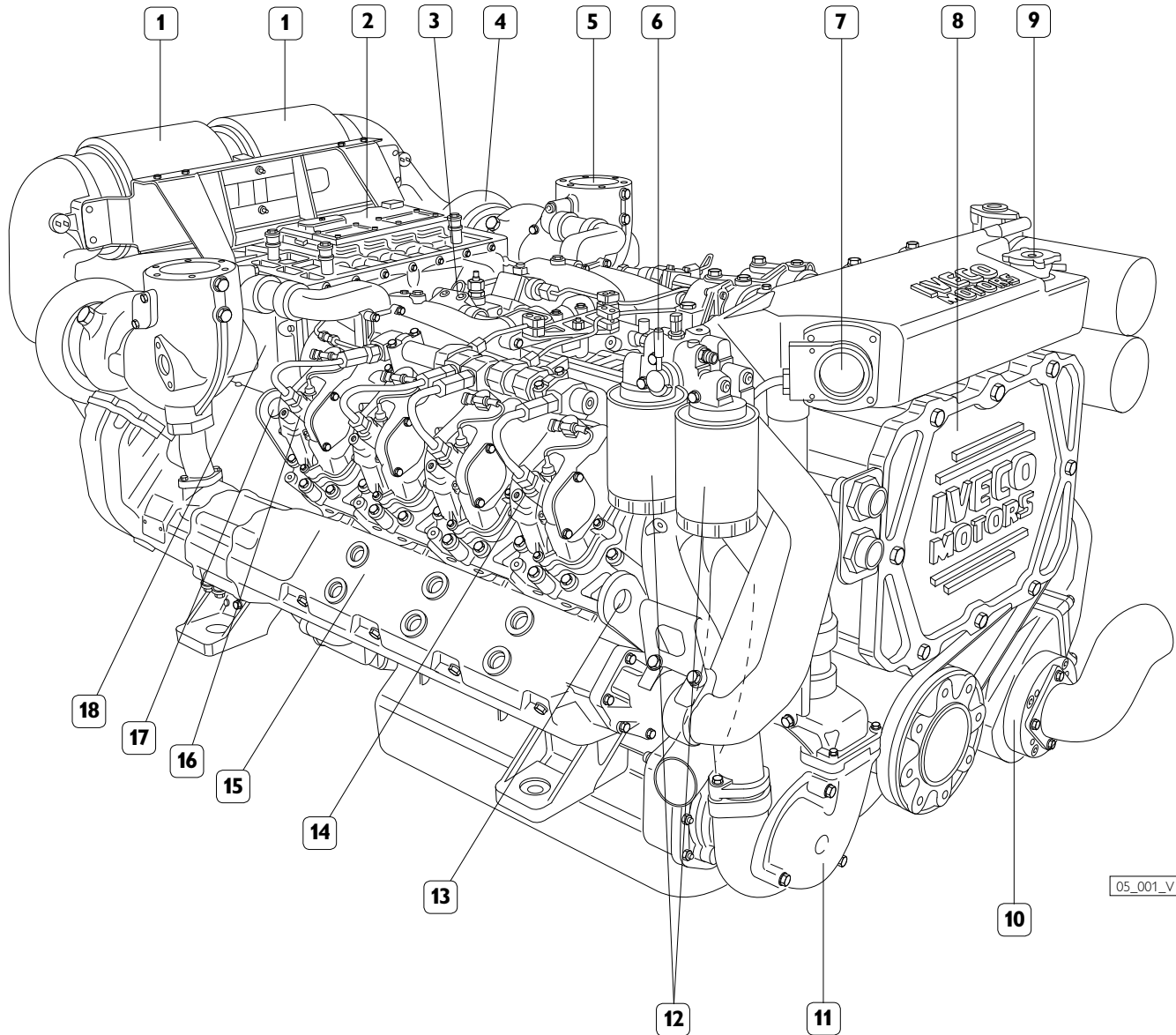

05\_001\_V

1. Intake air filter - 2. EDC Electronic Central Unit - 3. Common rail high pressure injection pump - 4. Cooled turbo-charger - 5. Exhaust gas outlet - 6. Lever for switching fuel filters - 7. Engine coolant level sensor - 8. Water/water heat exchanger - 9. Pressurization cap for coolant tank - 10. Sea water pump - 11. Engine coolant pump - 12. Fuel filters - 13. Lifting padeyes - 14. Cylinder 1 electro-injector - 15. Cooled exhaust manifold - 16. Cylinder 4 electro-injector - 17. Lifting padeyes - 18. Air-sea water heat exchanger.

Figure 1B

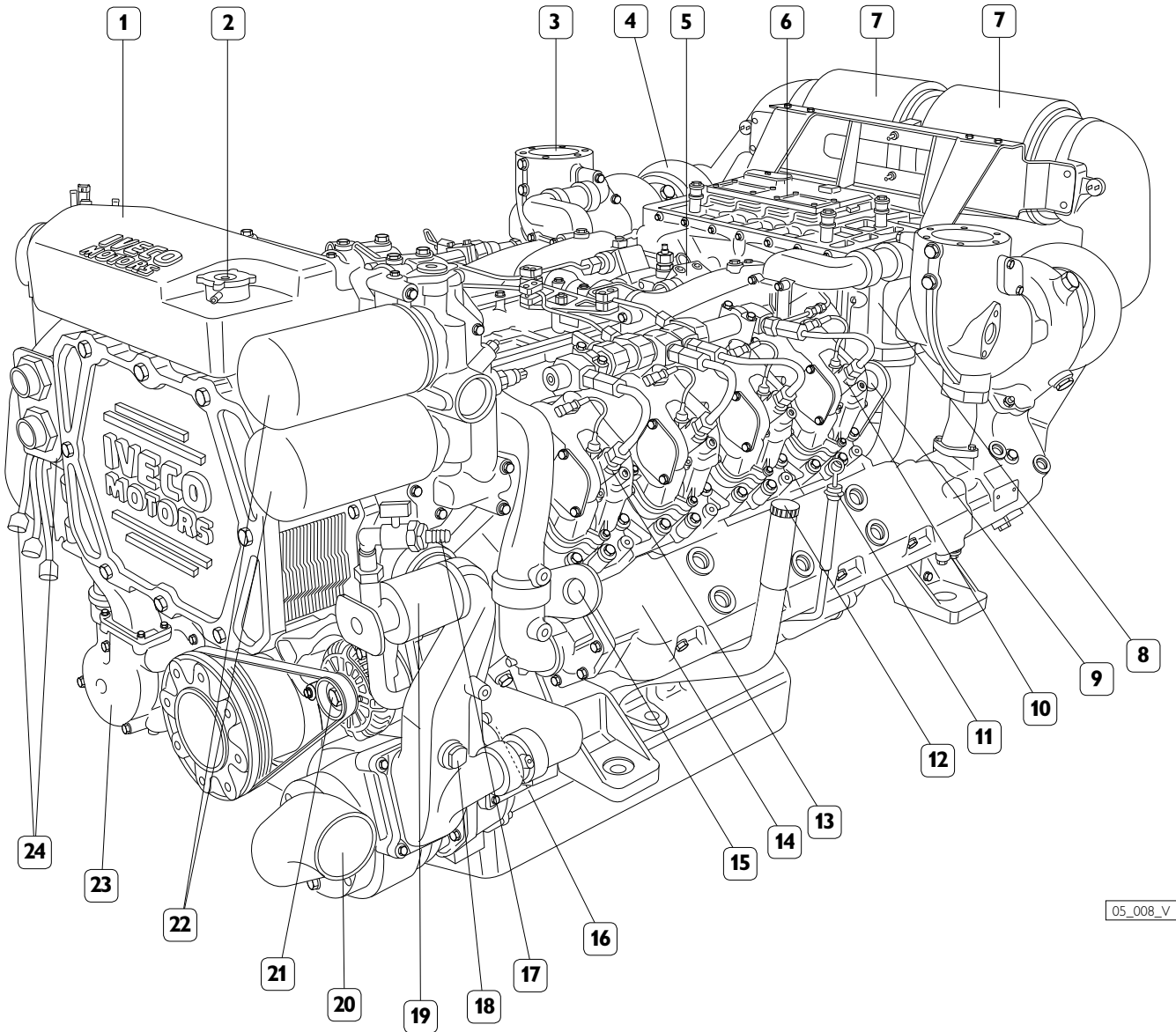

05\_008\_V

1. Engine coolant tank - 2. Pressurization cap for coolant tank - 3. Exhaust gas outlet - 4. Cooled turbo-charger - 5. Common rail high pressure injection pump - 6. EDC Electronic Central Unit - 7. Intake air filter - 8. Air-sea water heat exchanger - 9. Lifting padeyes - 10. Cylinder 8 electro-injector - 11. Lubricating oil dipstick - 12. Lubricating oil refill cap - 13. Cylinder 5 electro-injector - 14. Cooled exhaust manifold - 15. Lifting padeyes - 16. Location of the low pressure fuel transfer pump - 17. Tap and fitting for lubricating oil transfer - 18. Sacrificial anode - 19. Lubrication oil transfer electrical pump - 20. Sea water intake - 21. Alternator - 22. Lubricating oil filters - 23. Engine coolant pump - 24. Electrical equipment wiring connectors.



Figure 2A

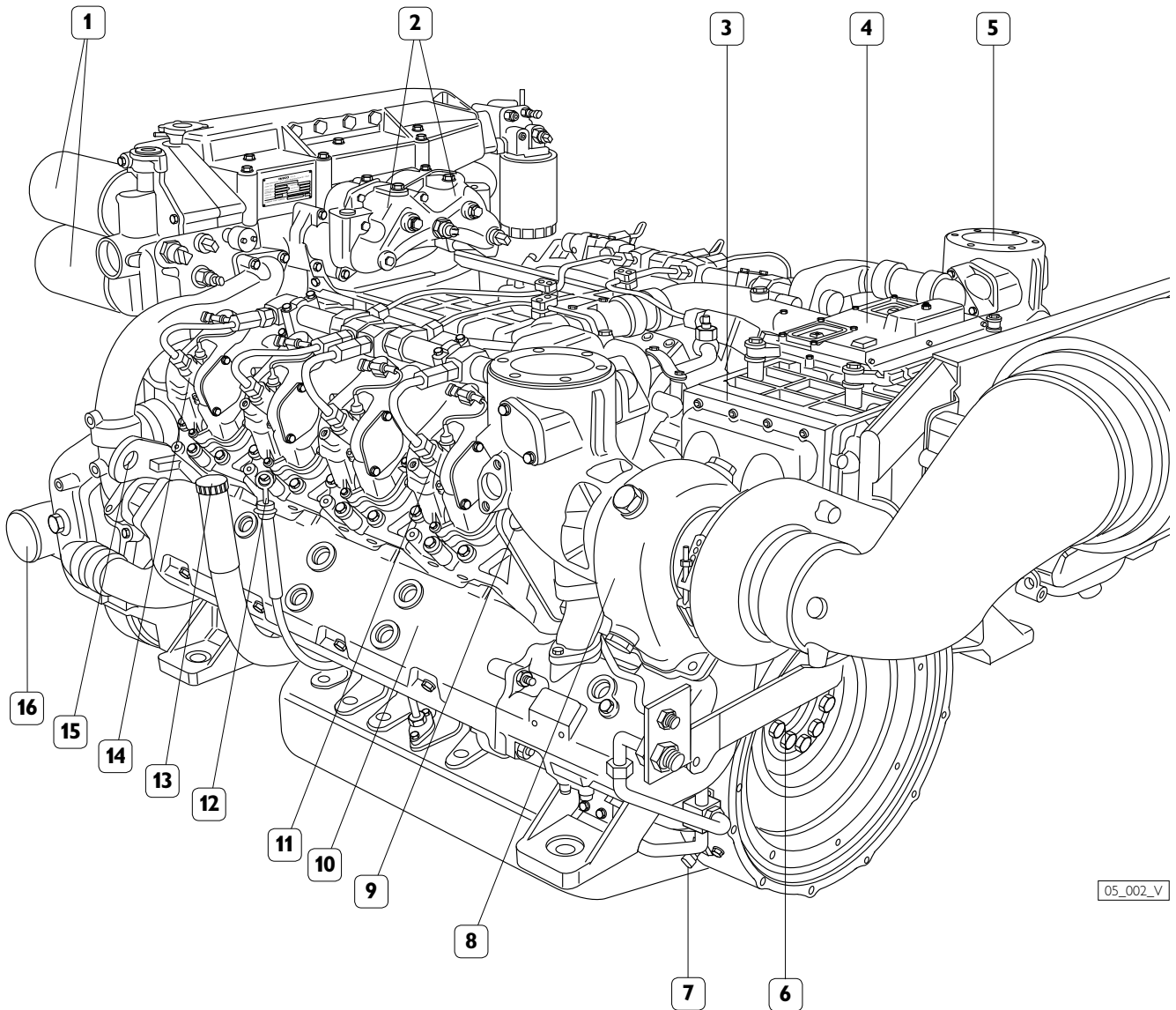

05\_002\_V

1. Lubricating oil filters - 2. Location of thermostatic valves - 3. Air-sea water heat exchanger - 4. EDC Electronic Central Unit - 5. Exhaust gas outlet - 6. Fuel inlet and outlet fittings - 7. Crankshaft sensor - 8. Cooled turbo-charger - 9. Lifting padeyes - 10. Cooled exhaust manifold - 11. Cylinder 8 electro-injector - 12. Lubricating oil dipstick - 13. Lubricating oil refill cap - 14. Cylinder 5 electro-injector - 15. Lifting padeyes - 16. Sea water intake.



Figure 2B

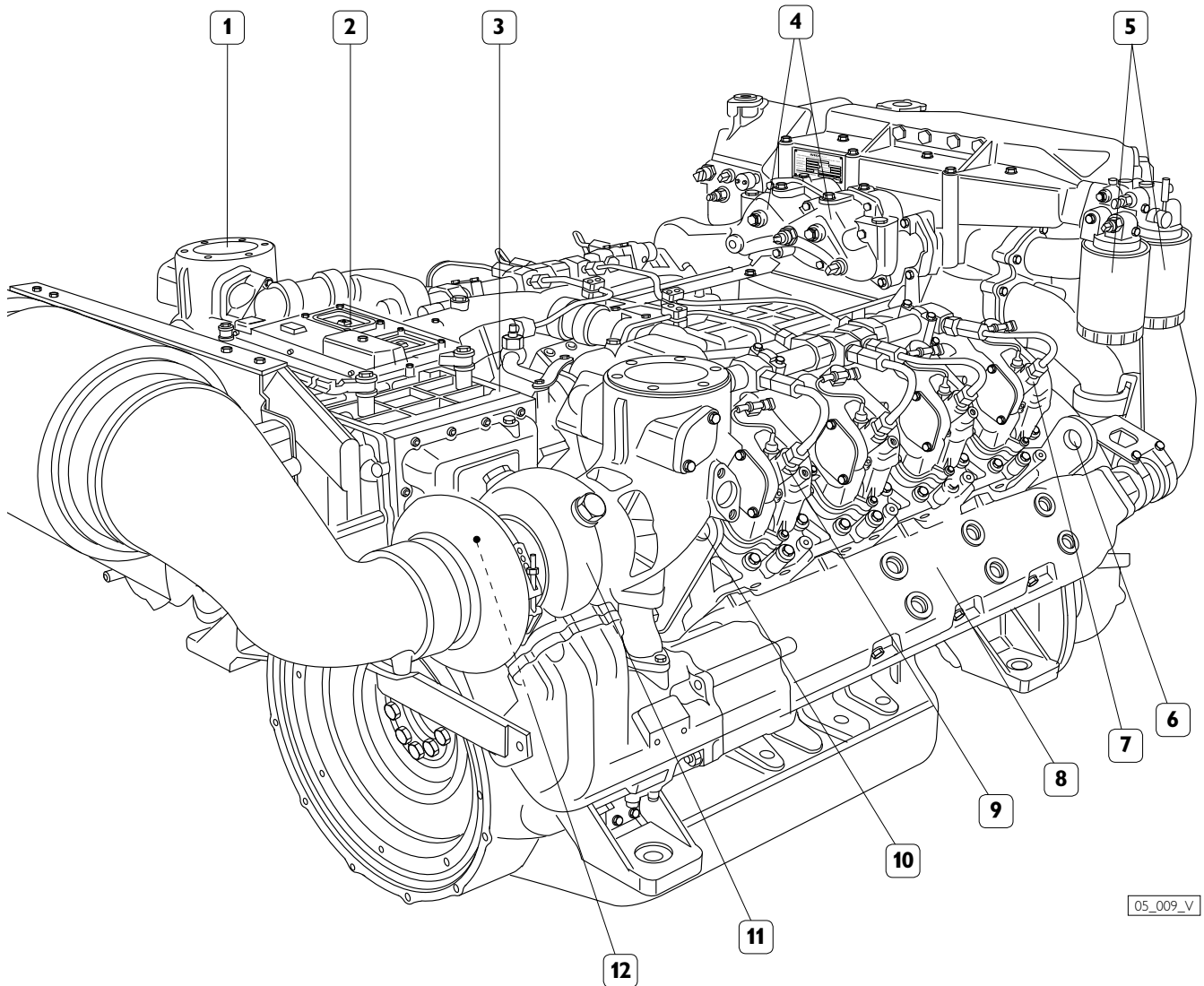

05\_009\_V

1. Exhaust gas outlet - 2. EDC Electronic Central Unit - 3. Air-sea water heat exchanger - 4. Location of thermostatic valves -  
5. Fuel filters - 6. Lifting padeyes - 7. Cylinder 1 electro-injector - 8. Cooled exhaust manifold - 9. Cylinder 4 electro-injector -  
10. Lifting padeyes - 11. Cooled turbo-charger - 12. Sacrificial anode (placed on the air/water heat exchanger).

### 3. INSTALLATION OVERVIEW

Figure 3

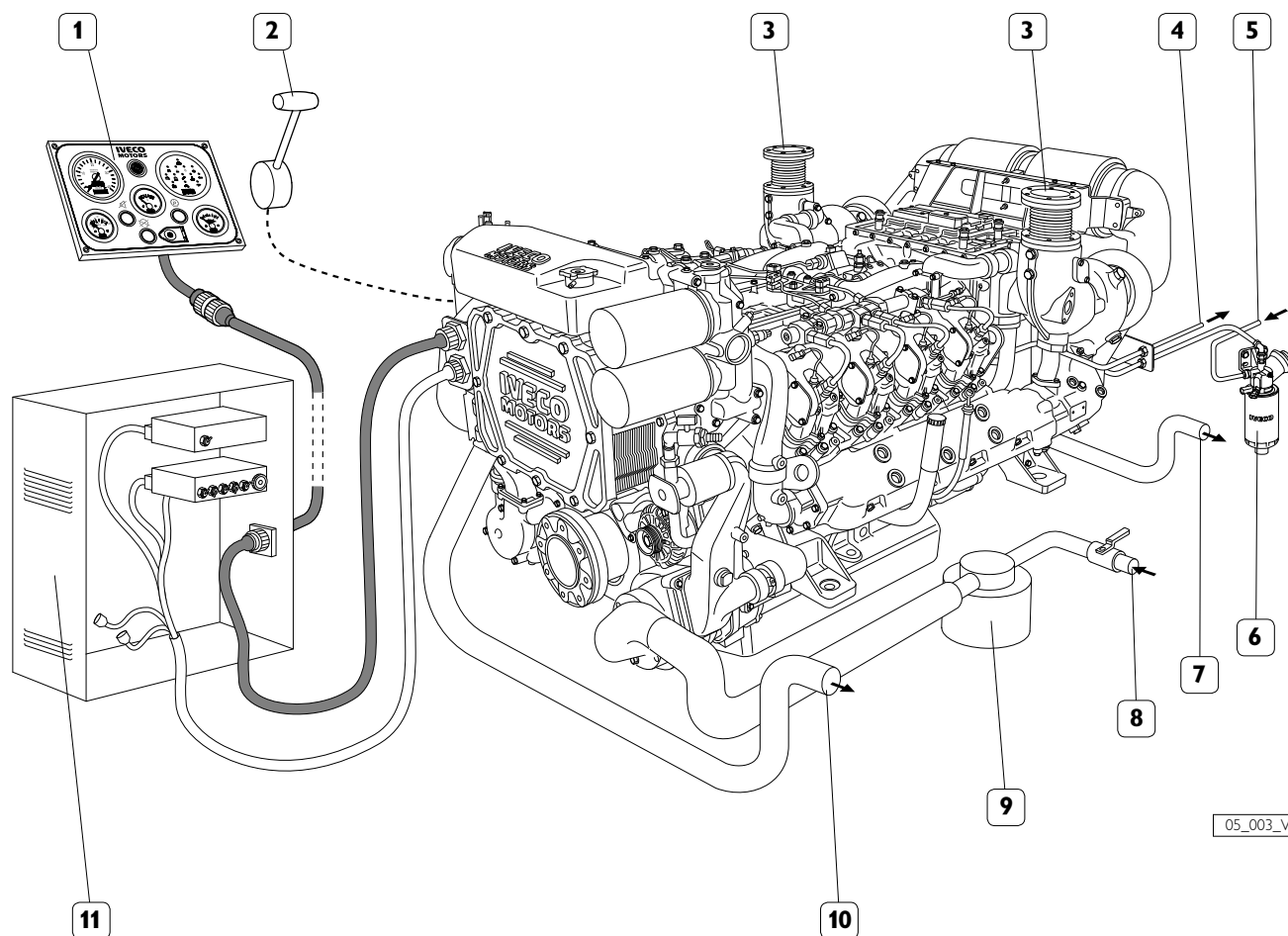

05\_003\_V

1. Main instrument panel - 2. Throttle actuator - 3. Exhaust gas outlet - 4. Fuel return pipe to tank - 5. Fuel suction pipe - 6. Prefilter with priming pump - 7. Sea water outlet from air/water heat exchanger - 8. To the filtered sea water intake - 9. Sea water decanter filter - 10. Sea water outlet from water/water heat exchanger - 11. Electrical system cabinet.

The figure shows the set of components of an installation, including those supplied with the engine equipment, standard or optional, and those supplied or produced by the yard. It provides a comprehensive picture of the operations required to install the engine.

Components arrangement and illustrations are not binding but merely indicative, subject to the choices made by yard engineers according to their skills, available spaces and the prescriptions set out herein.

## 4. GENERAL INSTALLATION CRITERIA

### Accessibility

The engine must be located in such a way as to allow filling and draining engine liquids when doing servicing operations. Moreover, the relay box and the diagnostic push-button present on it must be accessible, also when underway.

### Anchoring

If anchoring is accomplished by interposing shock mounts, they must be able to support the engine's mass and the longitudinal thrust exerted by the propeller shaft in motion.

If rigid mounting is adopted, particular care must be given to support alignment and co-planarity.

Information on dimensions and fastening values are provided in the "Installation Diagram".

### Combustion and ventilation air

Compliance with prescriptions on the quantity of air required for combustion and ventilation assures a regular operation of the engine even in adverse conditions and it enables to deliver its maximum rated power (1).

### Sea water line

It must be provided with an intake capable of preventing the entry of foreign bodies into the suction pipes. Between the intake and the pump, it is best to interpose a gate to be closed in emergencies or for extended idle periods and a filter to stop the smaller impurities; it is also recommended to install a suitably dimensioned and easily replaced zinc anode.

The engine sea water line was provided by the manufacturer with protection anodes to be replaced periodically.

The rubber hoses positioned along the pipeline shall be sufficiently rigid not to create choked areas caused by crushing (1).

### Engine pre-heating

If the engine usage profile requires immediate delivery of power at the highest rpm's, it is recommended to install an auxiliary pre-heater on the closed cooling loop.

### Exhaust gas outlet

The exhaust gas outlet conduits shall be compliant with the guidelines contained in the IVECO MOTORS publication "Guide to the installation of marine engines"; it also provides indications to compute the dimensions of the exhaust pipelines, which is the Yard's responsibility.

### Electric - electronic equipment

Provide a suitable arrangement of the relay box, and of the optional electronic unit referring to the dimensions and position of the wire harnesses and the relative connectors.

Both units must be anchored in such a way as to dampen the vibrations and stresses undergone by the hull while underway and/or induced by the engine's operation.

**NOTE:** Information about optional equipment are described in the Chapter 21.

- (1) The EDC engine electronic control is programmed to reduce maximum deliverable power if the operating parameters measured by the sensors show that critical conditions have been reached, and if exceeded the engine could be damaged.

## 5. TECHNICAL DATA FOR INSTALLATION

		V08 ENT M75	V08 ENT M11	V08 ENT M12
<b>Engine intake and ventilation air when underway</b>				
Static vacuum allowed downstream of the air filter	kPa mmH <sub>2</sub> O	≤ 3.5 ≤ 350	≤ 3.5 ≤ 350	≤ 3.5 ≤ 350
Engine air intake flow rate	m <sup>3</sup> /h	≥ 3050	≥ -	≥ 4000
Engine room ventilation air flow rate (excluding engine air intake)	m <sup>3</sup> /h	≥ 7950	≥ -	≥ 6600
Static vacuum allowed in the engine room	kPa mmH <sub>2</sub> O	≤ 0.1 ≤ 10	≤ 0.1 ≤ 10	≤ 0.1 ≤ 10
Temperature allowed in the engine room	°C	≤ 45	≤ -	≤ 40
Maximum engine room temperature exceed outside temperature	°C	≤ 15	≤ 15	≤ 15
<b>Exhaust gas outlet</b>				
Allowed static back pressure	kPa mmH <sub>2</sub> O	≤ 10 ≤ 1000	≤ 10 ≤ 1000	≤ 10 ≤ 1000
Temperature at maximum power (turbocharger inlet)	°C	510 ± 25	-	660 ± 25
Flow rate at maximum power	kg/h	3550	-	4800
Riser outer diameter	mm inches	- -	- -	- -
Dry exhaust outer diameter	mm inches	105 4	105 4	105 4
Diameter of circumference of distance between 6 locking holes	mm inches	127 5	127 5	127 5
<b>Fuel supply</b>				
Low pressure pump delivery at maximum rpm	l/h	400	400	400
Fuel temperature to allow maximum power	°C	≤ 70	≤ 70	≤ 70
Inner diameter, intake pipe	mm	≥ 14	≥ 14	≥ 14
Inner diameter, return pipe	mm	≥ 8	≥ 8	≥ 8
Thread on prefilter fittings	M	14 × 1.5	14 × 1.5	14 × 1.5
Thread on engine fittings	inches UIC	1/2	1/2	1/2
Allowed intake vacuum	kPa mmH <sub>2</sub> O	≤ 50 ≤ 5000	≤ 50 ≤ 5000	≤ 50 ≤ 5000
Allowed intake pressure	kPa mmH <sub>2</sub> O	≤ 20 ≤ 2000	≤ 20 ≤ 2000	≤ 20 ≤ 2000
<b>Open sea water cooling line</b>				
Intake pipe outer diameter	mm inches	101 4	101 4	101 4
Pump delivery at maximum rpm	l/h	61000	-	78000
Allowed intake vacuum	kPa mmH <sub>2</sub> O	≤ 20 ≤ 2000	≤ 20 ≤ 2000	≤ 20 ≤ 2000
Discharge pipeline outer diameter from air/water heat exchanger	mm inches	51 2	51 2	51 2
Discharge pipeline diameter outer from water/water heat exchanger	mm inches	89 3½	89 3½	89 3½

		V08 ENT M75	V08 ENT M11	V08 ENT M12
<b>Gear box oil heat exchanger</b>				
Thread on the intermediate engine fittings	inches UIC	-	-	-
<b>Allowed engine inclination angles</b>				
Maximum longitudinal in continuous operation (static + dynamic)	degrees/360	+20°	+20°	+20°
Maximum transversal in continuous operation (static + dynamic)	degrees/360	± 22°30'	± 22°30'	± 22°30'
Longitudinal for lubricating oil level check with standard dipstick	degrees/360	0 ÷ 10°	0 ÷ 10°	0 ÷ 10°
<b>Power takeoffs (optional)</b>				
<b>2-race front pulley for "V" belts</b>				
Reference diameter	mm	-	-	-
Race dimension	mm	-	-	-
Power available per belt at 650 rpm	kW	-	-	-
	CV	-	-	-
Power available per belt at 1300 rpm	kW	-	-	-
	CV	-	-	-
<b>2-race front pulley + elastic joint for flange</b>				
Torque available in engine axis	Nm	-	-	-
	kgm	-	-	-
<b>2-race front pulley + elastic joint for crankshaft</b>				
Torque available in engine axis	Nm	-	-	-
	kgm	-	-	-
Radial force resulting from belt tension (*)	N	-	-	-
(*) For direction of the resulting radial force between 60° and 300° with reference to vertical axis				
Moment of inertia of rigidly added masses (*)	kgm <sup>2</sup>	-	-	-

**Dimensions**

Figure 4

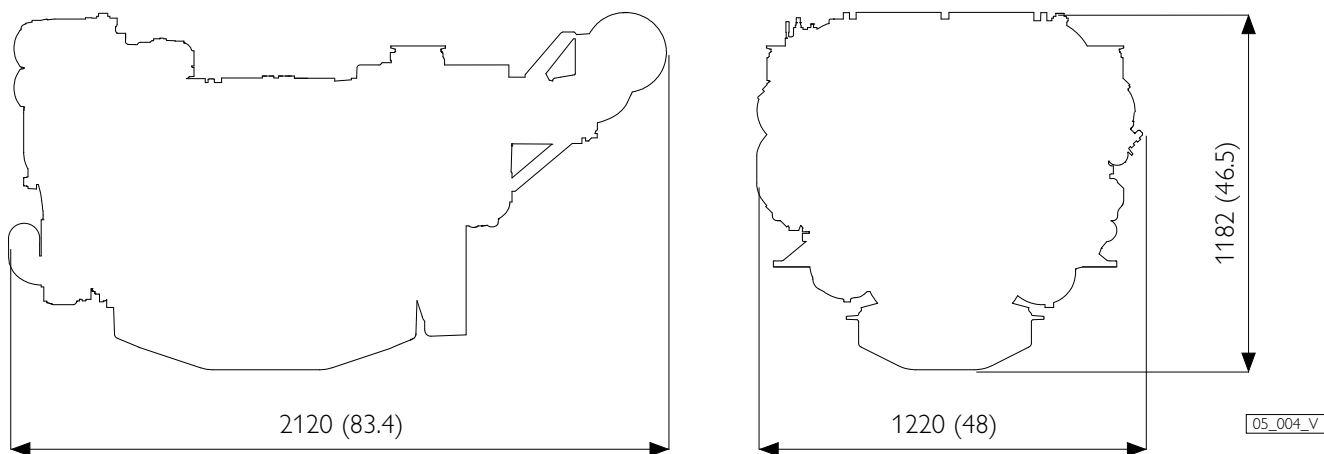

Dimension in millimetres (inches)

## 6. IDENTIFICATION DATA

Figure 5

<b>IVECO</b> S. p. A.	
Viale dell'Industria, 15/17 - 20010 Pregnana Mil.se MI - ITALY	
ENGINE TYPE	<input type="text"/>
ENGINE FAMILY	<input type="text"/>
ENGINE DWG	<input type="text"/>
POWER (KW) AND SPEED (RPM)	<input type="text"/>
POWER SET CODE	<input type="text"/>
ENGINE S/N	<input type="text"/>
YEAR OF BUILD	<input type="text"/>
HOMOLOGATION	<input type="text"/>
N°	<input type="text"/>
COMMERC. TYPE / VERSION	<input type="text"/>

04\_039\_C

Figure 6

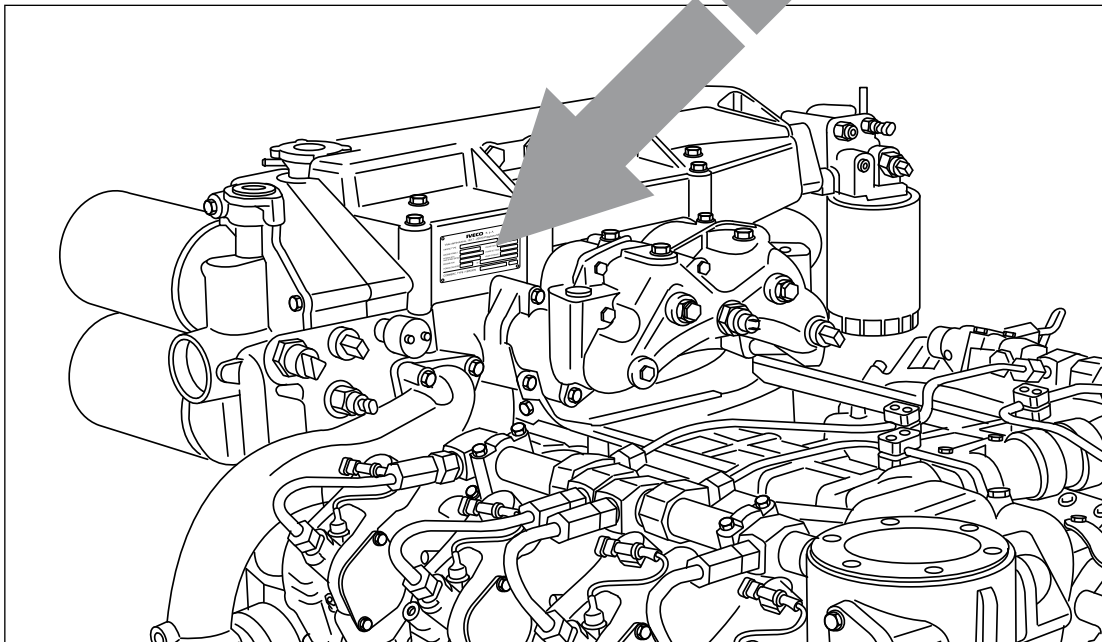

05\_002\_V

The engine identification data are stenciled on a tag positioned over the engine coolant tank

## 7. FUEL LINE

Figure 7

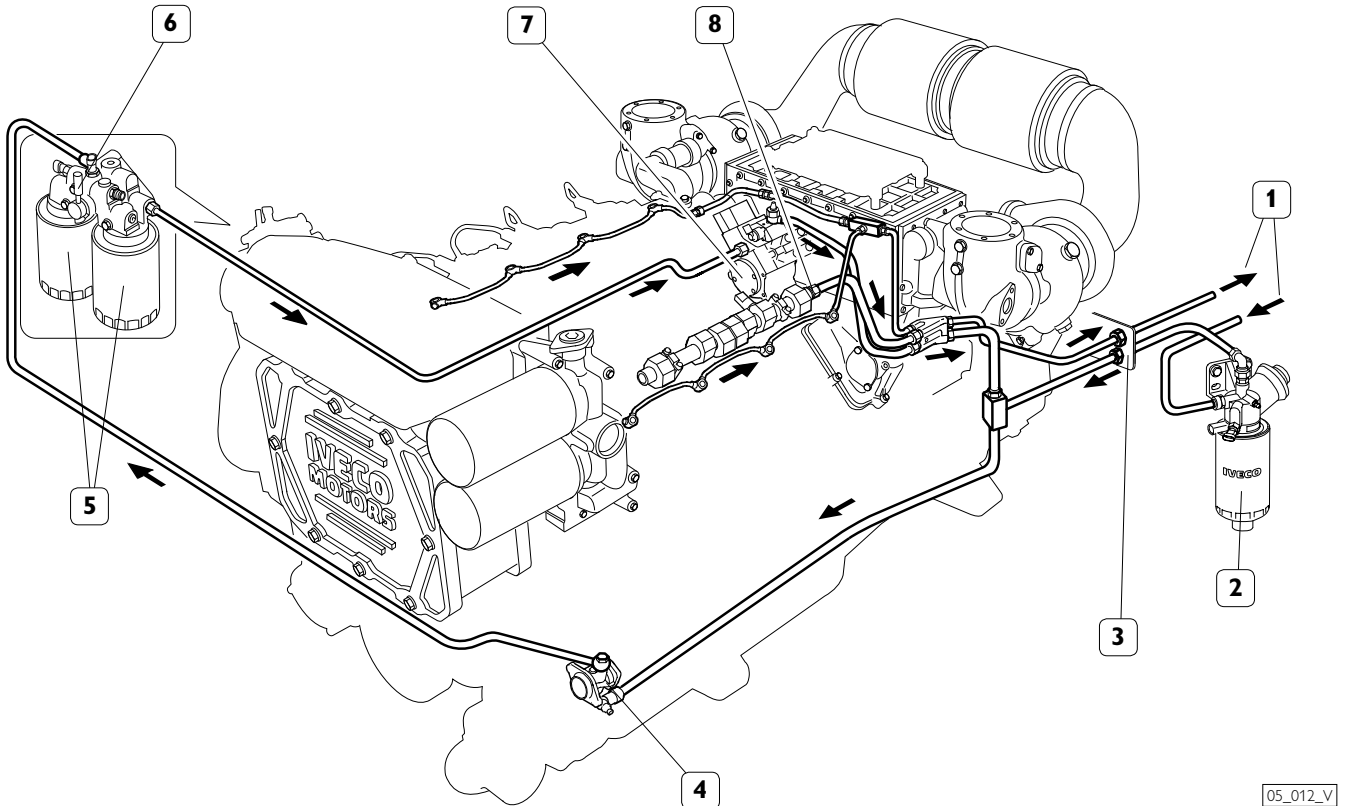

1. Return and suction flows from the tank - 2. Prefilter - 3. Fuel fitting support - 4. Low pressure supply pump - 5. Fuel filters - 6. Lever for switching fuel filters - 7. Common rail high pressure injection pump - 8. Rail overpressure valve.

For the installation, the following connections are required:

- from the tank to the prefilter
- from the prefilter to fitting to engine inlet
- from engine outlet fitting to the tank recirculation

### Prefilter

The prefilter with priming pump, supplied separately from the engine, must be fastened near the tank, in a relatively low point of the line to allow for easy replacement the filtering cartridge and/or the operation of the hand pump. Avoid the use of additional mesh or paper filters along the feed lines between prefilter and engine. To avoid introducing impurities in the feeding lines inside the engine, do not place filter cartridges pre-filled with fuel in the system.

### Materials Characteristics

The fuel tank and the suction and return assembly must withstand the continuous abrasion caused by a flow of fuel oil of 250 l/h at a temperature of 90°C without noticeable deformation or wear or release of material. Use of metal tanks, preferably made of iron alloys, is allowed, provided

they are connected to the negative terminal of the battery to prevent the accumulation of electrostatic charges.

Tanks must be provided with vents to avoid exceeding an internal pressure of  $\pm 5\text{kPa}$  ( $\pm 0.5\text{ m}$  of  $\text{H}_2\text{O}$  column); their shape and the suction assembly must be such as to assure a suction at the maximum longitudinal and transverse inclination allowed for the boat, with a residual quantity of fuel oil considered "reserve".

The suction inlet should be positioned in such a way as to avoid taking in sludge. The return flow must be in such a way as to facilitate the mixing of the returning fuel with the fuel in the tank. If the tank is lower than the filter, then the return pipe must always be submerged. The pipes and union fittings of the fuel line must withstand a fuel oil flow rate of 250 l/h at a temperature of 90°C and a pressure of 3 bar (300 kPa) without noticeable deformation, wear or release of material. Metal tubes, preferably made of iron alloys, are recommended, taking care to connect each individual segment to engine ground to avoid the accumulation of electrostatic charges and inserting a vibration damper elastic joint on each segment. The pipes used must be certified according to the relevant Countries' rules or to the standards issued by classification Bodies.



## Fuel supply system scheme

Figure 8

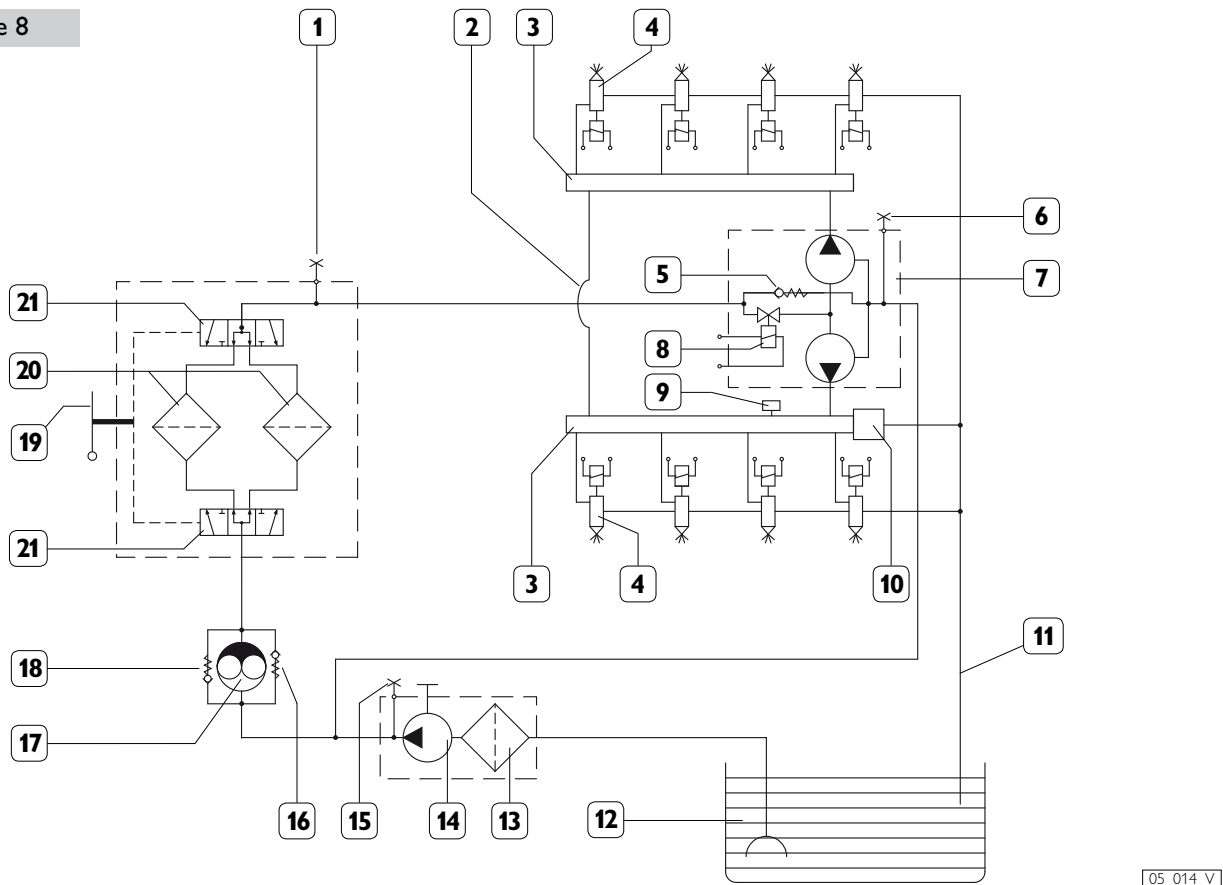

05\_014\_V

1. Vent fitting - 2. Compensation duct between two rails - 3. Common rail - 4. Electro-injector - 5. Low pressure limiter valve - 6. Vent fitting - 7. Twin-cylinder high pressure pump - 8. Pressure control solenoid valve - 9. Pressure sensor - 10. Common rail overpressure valve - 11. Low pressure recirculation duct - 12. Fuel tank - 13. Prefilter - 14. Manual priming pump - 15. Vent fitting - 16. Recirculation valve for low pressure pump - 17. Low pressure mechanical feed pump - 18. By-pass valve for low pressure pump - 19. Lever for switching filters - 20. Fuel filters - 21. Filter exclusion valves.

## Hydraulic connections

Figure 9

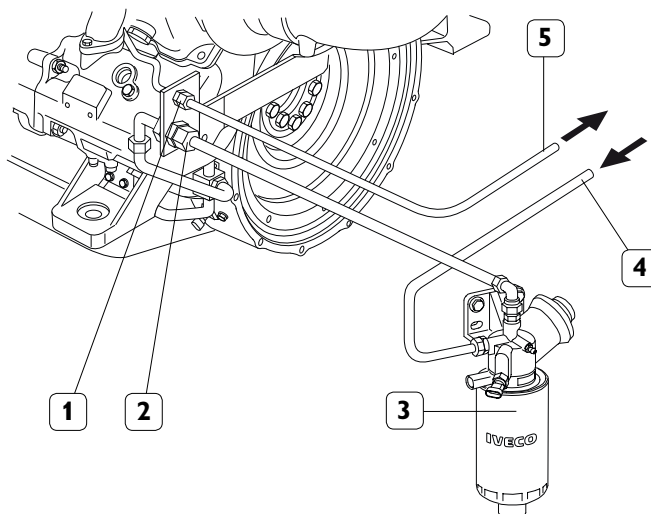

05\_015\_V

1. Fitting for fuel outflow to the tank - 2. Fitting for fuel inflow from prefilter - 3. Prefilter - 4. Fuel inlet pipe from the tank - 5. Fuel return pipe to the tank.

## 8. ELECTRICAL EQUIPMENT

Figure 10

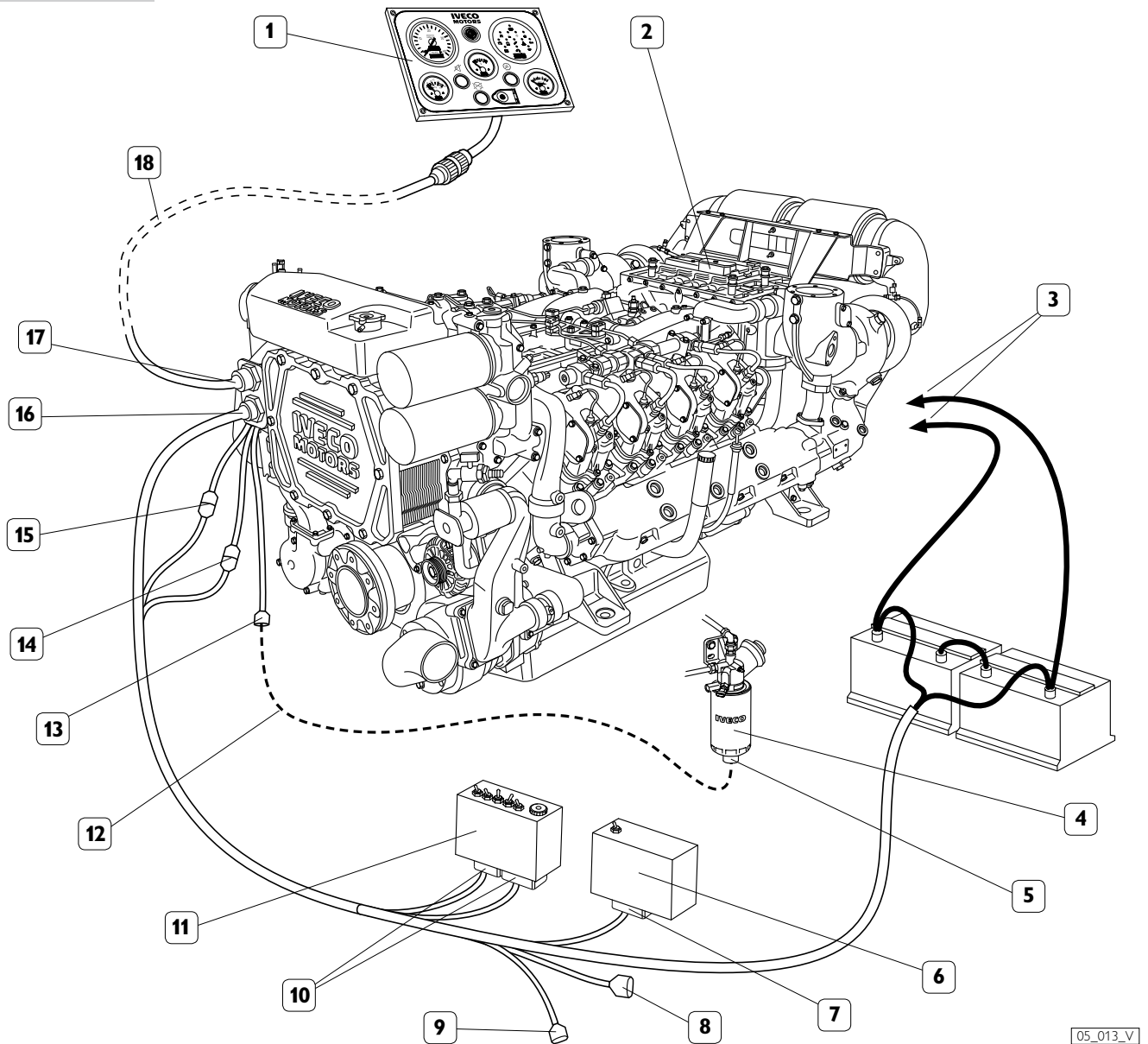

1. Indicator and control panel - 2. Electronic Central Unit - 3. Power line for electric starter motor and alternator - 4. Sedimenting prefilter - 5. Sensor to detect the presence of water in the fuel - 6. Control unit of the lubrication oil transfer electrical pump - 7. JG Connector - 8. JG1 Connector for control unit of the lubrication oil electrical pump - 9. JC Connector - 10. JF1 and JF2 connectors - 11. Relay box - 12. Wiring harness to be manufactured by the yard - 13. M Connector - 14. J4 Connector for the electrical pre-lubrication pump - 15. J3 Connector for the electrical lubricating oil pump - 16. JA Connection - 17. JB Connection - 18. Instrument panel wire harness.

The electrical equipment of the engine comprises a series of components provided separately from the engine to enable an easy and diversified installation, according to the Yard's design choices. The need to make accessible, at sea or under-way, the controls to the electrical components and to the connector for diagnostics contained in the relay box may be met through different installation arrangements. Along with the coupling of all connectors provided in the wire harnesses, completing the installation also requires the

connecting wire harness (12) for the sensor to detect the presence of water in fuel (5), to complete the power line and to connect the accumulator to the engine wire harness. The connection of the J3 connector enables the electric connection of the control module to the lubricating oil pouring pump. The JC connector is set for the connection to the emergency stop button.



Wire harness

Figure 12

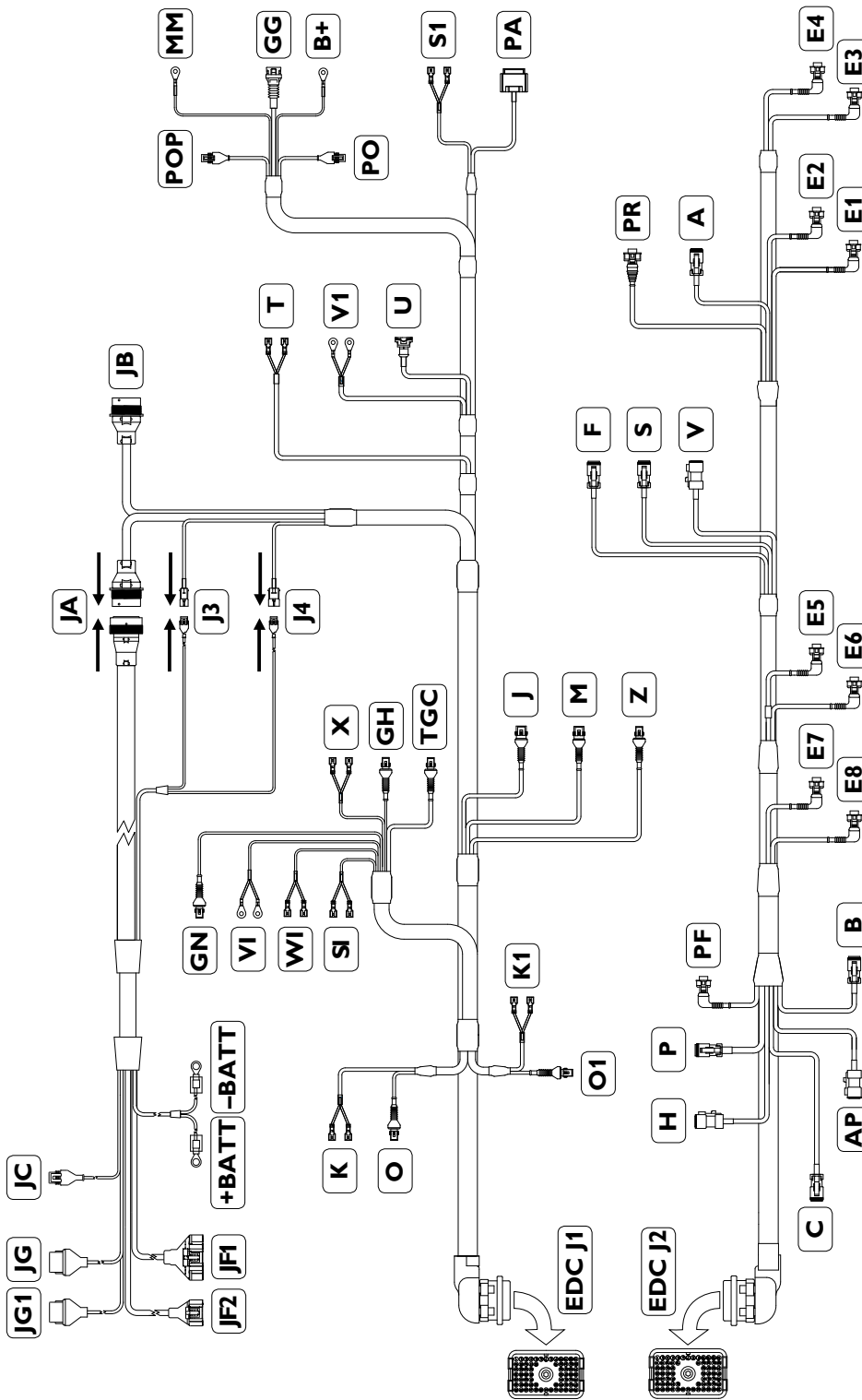

05\_005\_V

A. Fuel temperature sensor - AP. Atmospheric pressure sensor - B. Crankshaft sensor for EDC - C. Camshaft sensor - E1/E8. Electro-injectors - F. Engine coolant temperature sensor for EDC - GG. Alternator - GH. Grid heater power relay - GN. Neutral gear sensor (in installation with no sensor; do not remove the cap of the GN connector to avoid compromising start engine function) - H. Combustion air pressure sensor for EDC - J. Low coolant level sensor (for alarm) - JB. Instrument panel connection wire harness - JC. Emergency shut-off push-button (optional, installer's responsibility) - J3. Connector for lubrication oil transfer electrical pump - J4. Connector for pre-lubrication electrical pump - JF1, JF2. Relay box - JG. Lubrication oil transfer electrical pump control unit - JG1. Pre-lubrication electrical pump control unit - K/K1. Clogged air filter sensors (for alarm) - M. Sensor to detect water in the fuel prefilter (for alarm) - MM. Electric starter motor - O/O1. Exhaust gas temperature sensors (for gauge) - P. Combustion air temperature sensor for EDC - PA. Throttle position sensor - PF. Rail pressure control solenoid valve - PO. Lubrication oil transfer electrical pump - POP. Pre-lubrication electrical pump - PR. Rail pressure sensor for EDC - S1. Engine oil temperature sensor (for gauge) - S. Gear oil temperature sensor (for gauge) - T. Coolant temperature sensor (for gauge) - TGC. Power relay for electric starter motor insulation (provision) - U. Clogged oil filter sensor (for alarm) - V. Engine oil pressure sensor for EDC - V1. Engine oil pressure sensor (for gauge) - VI. Low gear oil pressure sensor - WI. Low gear oil pressure sensor - X. Clogged blow-by filter sensor - Z. Clogged fuel filter sensor (for alarm).

## Power supply line

The power network must be carried out in order to avoid using both the structure of engine and the structure of the hull (if this is metallic). For this purpose the electrical starter motor and the alternator required for this equipment are characterized by the presence of the terminals for electrical connections both with the positive and with the negative pole of the battery.

Figure 13

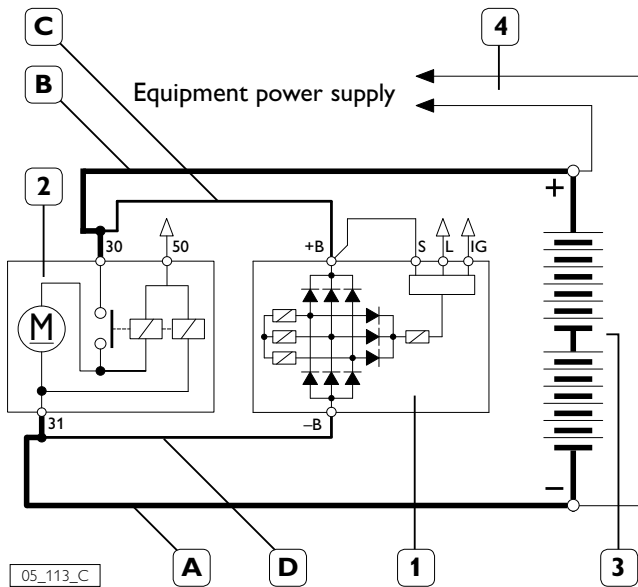

1. Alternator - 2. Electrical starter motor - 3. Battery -  
4. Engine wire harness.

The power supply line, to be built by the yard, comprises:

- ❑ A. Connection between the negative pole of the battery and the terminal “-B” of the electric starter motor realized with a conductor having a cross section of at least 95 mm<sup>2</sup>;
- ❑ B. Connection between the positive pole of the battery and the terminal “30” of the electrical starter motor realized with a conductor having a cross section of at least 50 mm<sup>2</sup>;
- ❑ C. Connection between the “30” terminal of the alternator to the positive “+B” terminal of the electric starter motor, to close the power supply and recharge circuit of the battery realized with a conductor having a cross section of at least 50 mm<sup>2</sup>.
- ❑ D. Connection between the “-B” terminal of the alternator to the positive “-B” terminal of the electric starter motor, to close the power supply and recharge circuit of the battery realized with a conductor having a cross section of at least 50 mm<sup>2</sup>.

The connection of the electric equipment of the engine to the battery has to be carried out via the two eyed terminals, “+B” and “-B”, present on the wiring harness.

## CAUTION

If magneto-thermal protecting breakers are installed on the wiring lines of the engine control system, they must not be used to stop the engine and in any case they must be activated only a few seconds after shut-off.

## Alternator

Figure 14

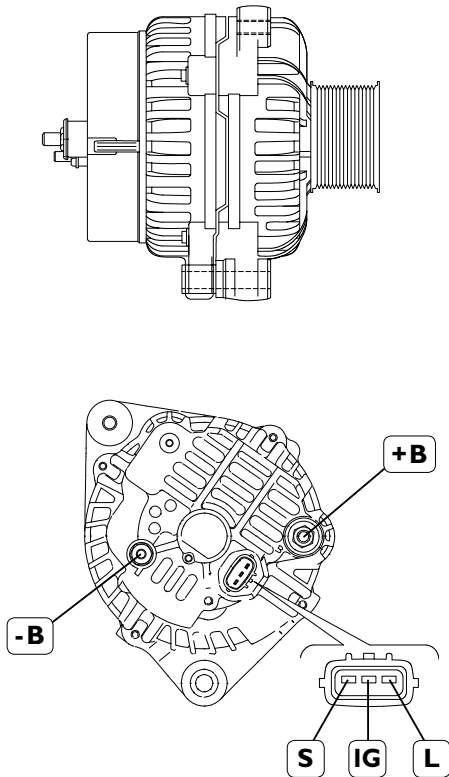

05\_112\_C

### Technical data:

- Nominal voltage 24 V
- Nominal current 90 A
- Terminal connection "+B" M8 x 1.25 tightening torque 12.5 Nm ± 20%
- Terminal connection "-B" M6 x 1 tightening torque 6.0 Nm ± 20%

- +B.** (24 V) Power supply output terminal
- B.** (0 V) Power supply output terminal
- S.** (Sense) Reference voltage of battery charge status (connected to "+B" terminal or to be connected to the positive pole of the battery in case of remote installation of the battery);
- IG.** (Ignition) Regulator enabling signal (connected to voltage "+ 15", driven by key switch);
- L.** (Lamp) Power supply voltage of recharge/alarm indicator light located on the panel.

## Electrical starting motor

Figure 15

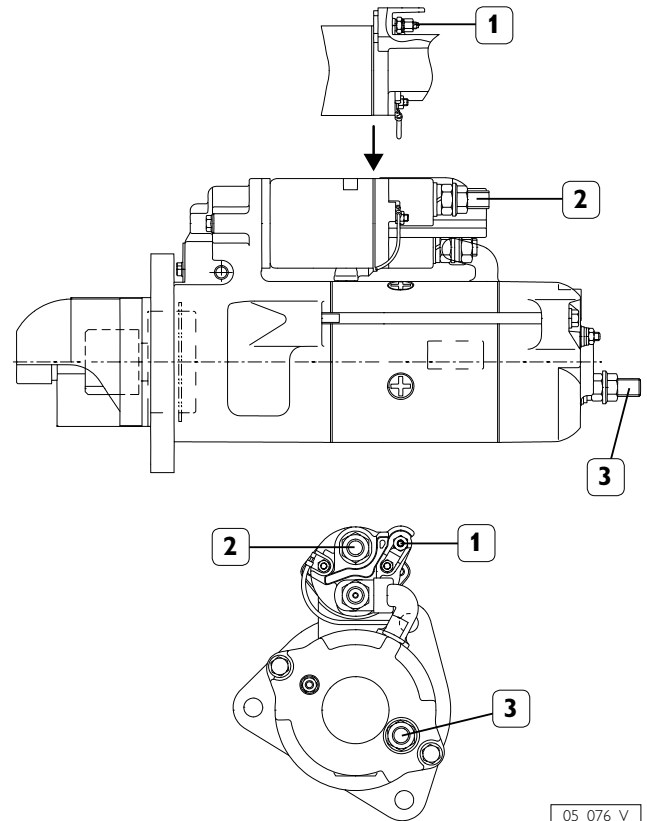

05\_076\_V

1. Excitation coil command (50) - 2. Positive power pole (+B) - 3. Negative supply pole (-B).

### Technical characteristics:

- Nominal supply voltage 24 V
- Absorbed power 8.5 kW
- Terminal connection "50" tightening torque 2 to 3 Nm
- Terminal connection "+B" tightening torque 20 to 30 Nm
- Terminal connection "-BATT" tightening torque 20 to 30 Nm

**Battery recharging**

**Figure 16**

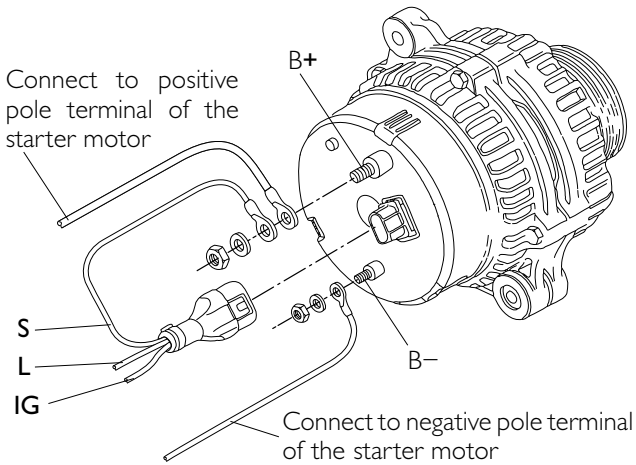

This is accomplished through the power supply line of the electric starter motor and connection to the +B of the alternator. The electronic regulator of the alternator that equips the engine allows an effective control over the battery recharging operation.

If, due to installation requirements, the batteries need to be positioned at a distance from the engine, we recommend increasing the cross section of the power line conductors and verifying recharging effectiveness by measuring voltage across the battery poles.

For the best control of the battery recharge cabling the line relating to the S terminal of the alternator directly to the positive pole terminal of the battery (see figure 17).

**Figure 17**

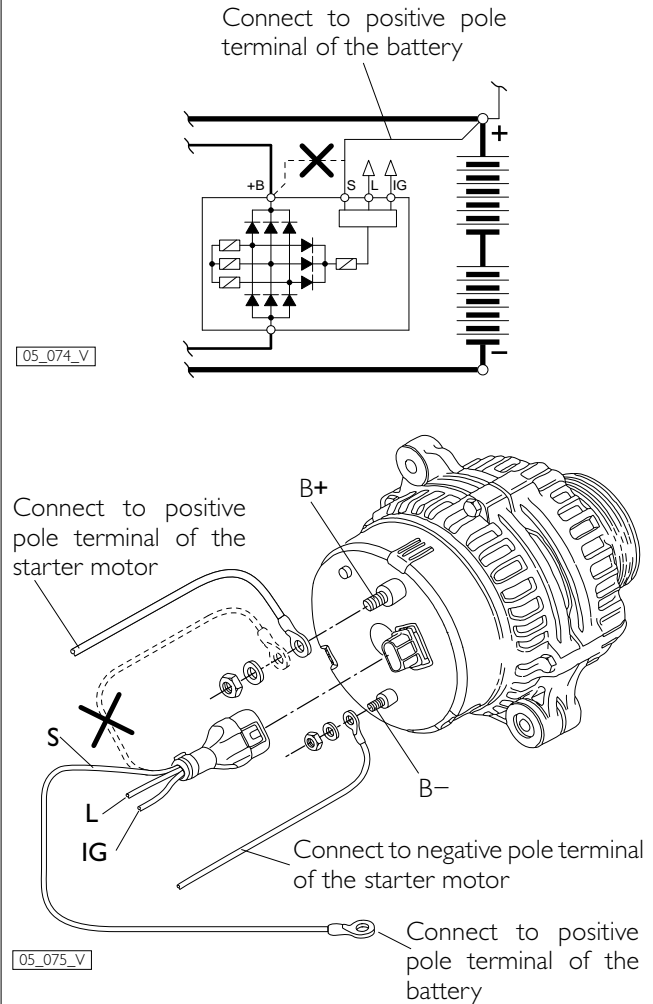



### Supplementary services battery

To assure that the engine can be started with a sufficient quantity of energy, it is advisable to provide for the installation of a supplementary battery, dedicated to supplying power to the on-board electrical services. The power line to recharge it may be constructed according to the indications provided in Chapter 20.

#### If one engine is installed

The battery used for services may be recharged interposing on the power supply line a relay actuated by the recharge signal of the alternator's electronic regulator (L).

#### If two engines are installed

The presence of two generators allows keeping the recharging functions separated: the generator (G1) recharges the battery (AC1) dedicated to starting both engines and powering both electrical/electronic control circuits, whilst the generator (G2) recharges the battery (AC2) used to power the services.

In two-engine applications, it is essential to connect the engine grounds to a common potential; the solution proposed in Chapter 20 fully complies with this need, assuring the full functionality and independence of the two circuits.

### Relay Box

Figure 18

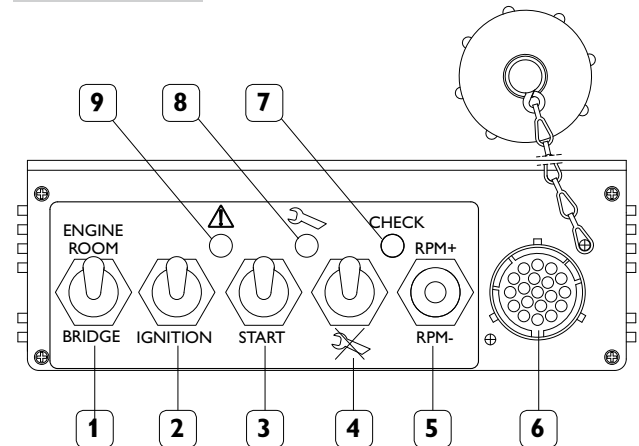

05\_007\_V

1. Control selector from bridge or engine room - 2. Power supply switch of the engine electric circuits - 3. Start button from engine room - 4. Reset button of the "maintenance alarm" - 5. Button for managing acceleration and deceleration - 6. Connector for diagnostic instrument - 7. Blink code emission LED (EDC) - 8. Signalling LED of maintenance interval expiration - 9. Signalling LED for fault engine operating parameters (WARNING).

This shall be installed and anchored in such a way as to dampen the vibrations and stresses occurring when underway, and they shall be accessible during servicing operations and when underway. The electrical commands positioned on the panel allow controlling engine starting and stopping directly from the engine room, while excluding any possibility that anyone may involuntarily start the engine from the bridge, during servicing operations.

On the relay box is located the multipolar connector (6), protected by a screw-on lid, for connection with the computerized diagnostic tools prescribed by IVECO MOTORS. Inside the box, anchored to a printed circuit board, are present the power management relays of some components and the elements that protect the electrical lines against short circuits or excessive current absorption. These components perform a similar function to that of fuses, almost totally avoiding the need to restore the electrical continuity of circuits subjected to an anomaly condition. These components are able to limit and eliminate short circuit currents without melting, restoring their own and the circuit's electrical continuity, once the cause of the anomaly is removed.

## Connections of the central electronic unit (ECU) ADEM III

Figure 19

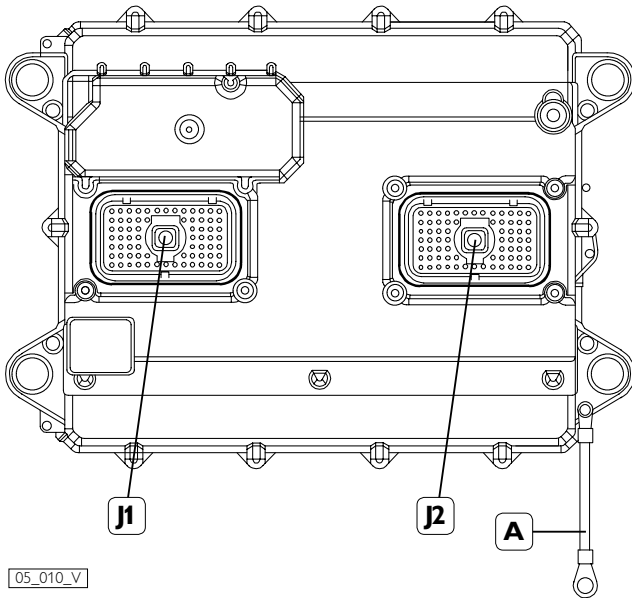

J1. Vessel side wiring connector - J2. Engine component wiring connector - A. Ground connection of the ECU.

The connection of the central electronic unit, ECU, to the EDC system, takes place by means of two 70-way connectors.

The presence of the two connectors provides for a subdivision of the wire harnesses to distribute the large quantity of conductors and at the same time favour a quicker identification of the lines during the service check operations carried out by technical assistance personnel.

The connectors are polarized and equipped with fixing screws to facilitate the insertion and disconnection operations and guarantee the link.

## Modality for inserting and disconnecting ECU connectors

Figure 20

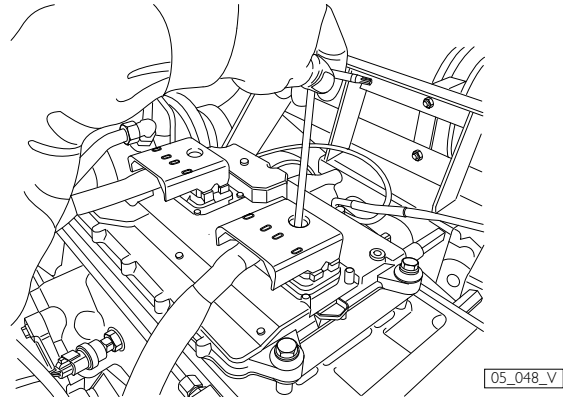

Both connectors are fastened to the ECU by means of 4 mm socket head screws. For the disconnection: loose the screw until the connector is completely free. For the insertion: fit the connector into the seat, fit the screw and tighten it firmly.

## Throttle lever position sensor

Figure 21

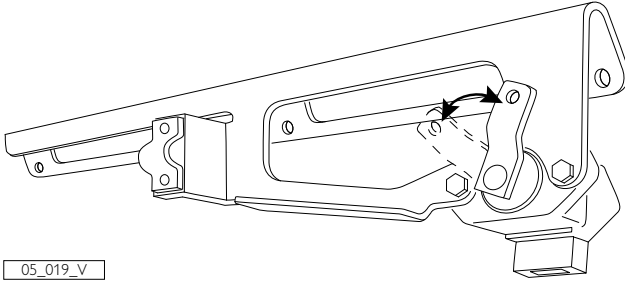

05\_019\_V

After testing the working condition of the linkage, adjust the run of the servo components (see Chapter 15).

- ❑ With the throttle at idle setting, the potentiometer rod has to be in the resting position;
- ❑ With the throttle at the stop, the potentiometer rod has to be in the position of maximum run out.

## Neutral gear sensor

### CAUTION

When neutral gear sensor is installed remember to connect it to GN connector.

In installation with no sensor, do not remove the cap of the GN connector to avoid compromising start engine function.

## Sensor to detect water in fuel

Figure 22

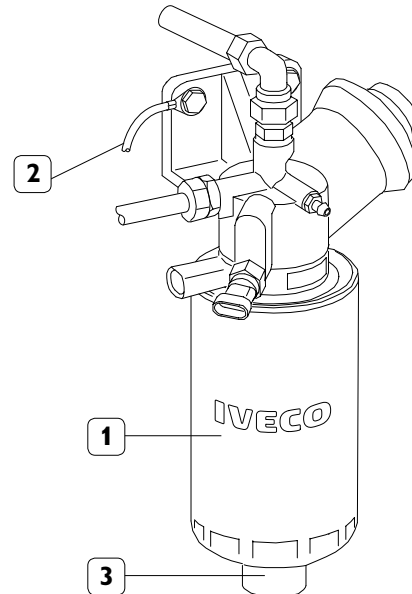

05\_018\_V

1. Prefilter - 2. Conductor to be connected with the negative battery terminal -
3. Sensor to detect water in fuel.

### CAUTION

In order to enable the proper working of the sensor to detect water in fuel, the prefilter support needs to be electrically connected to the negative battery terminal.

In the engine models which use parts with insulated poles it is necessary to electrically insulate the prefilter support from the boat mass and then connect the support with the negative battery terminal.

## 9. MAIN ANALOG INSTRUMENT PANEL

Figure 23

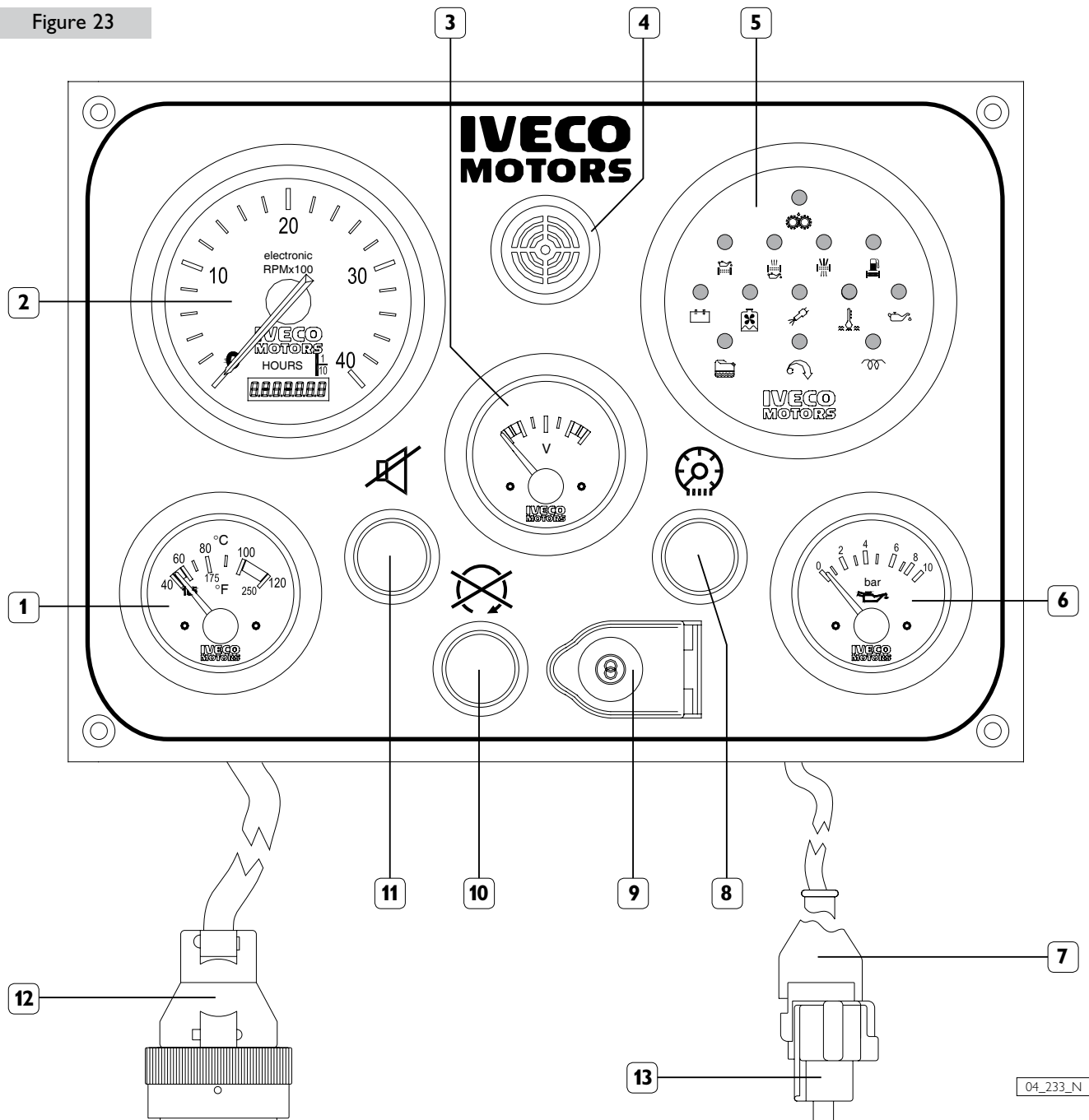

1. Coolant temperature gauge (TA) - 2. Revolution counter and hour counter (CG) - 3. Voltmeter (V) - 4. Buzzer (SA) - 5. Indications and alarms module (MS) - 6. Engine oil pressure gauge (MO) - 7. Connector for secondary instrument panel (JE) - 8. On board panel instrument light switch (L) - 9. Engine start/stop key switch (CA) - 10. Engine stop push-button (usable only on versions with excitation engine stop) - 11. Sound alarm inhibition push-button (P1) - 12. Connector for main panel wiring (JC) - 13. Cap with electrical continuity connection.

Installation of the IVECO MOTORS onboard panel with analog indicators entails connecting the panel's JC connector to the JB connector on engine wire harness, interposing the appropriate extension wire harness available in 3, 5 and 7 metre-long versions. The JC-JB wire harness comprises 47 lines, each connected to the terminal identified on both connectors by the same number.

To the main panel is connected the JE connector; provided for connection to the secondary panel; in installations without secondary panel, do not remove the cap of the JE connector to avoid compromising the electrical continuity of the systems' power supply circuit.

**Synoptic of the connections of the analog panels**

Figure 24

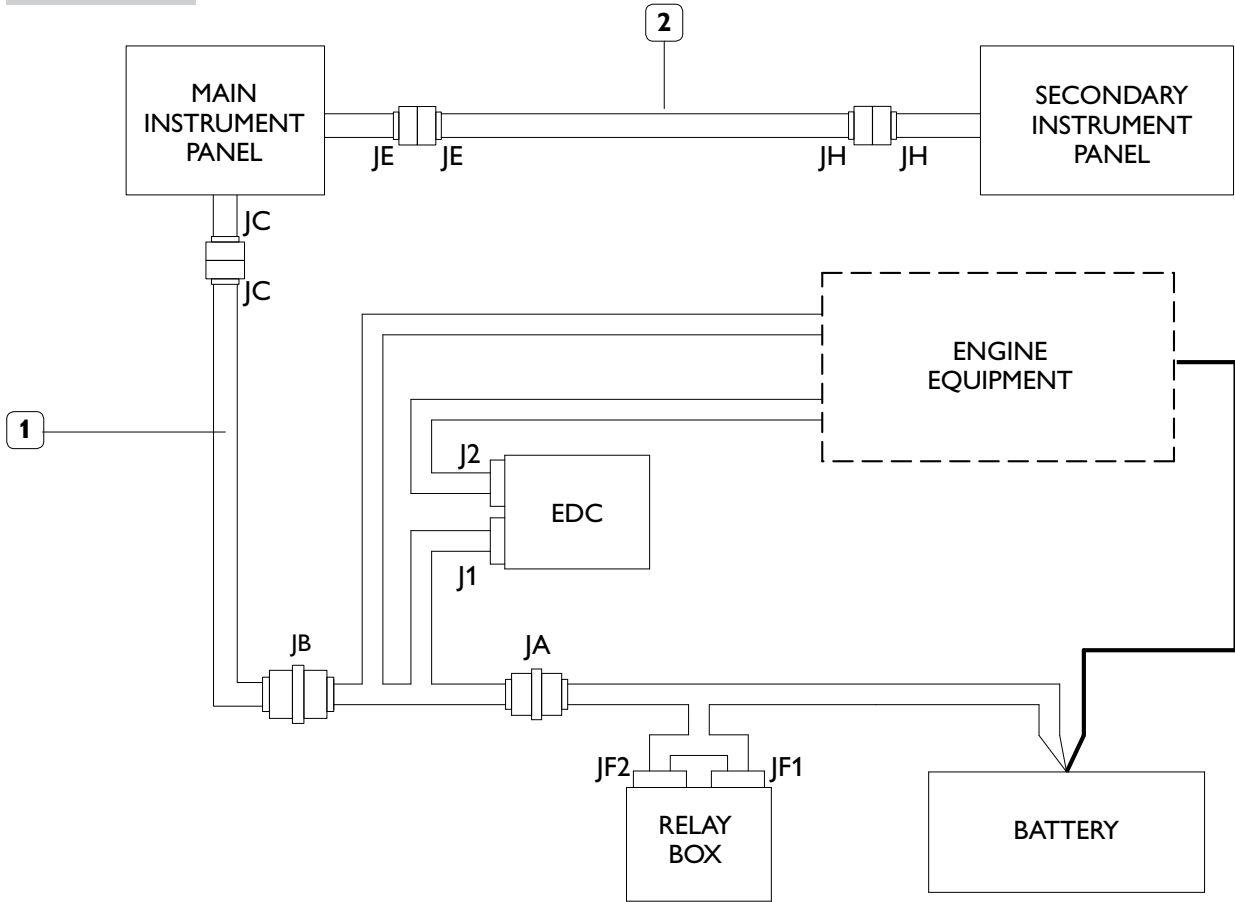

06\_131\_V

1. JB-JC Extension wire harness - 2. JE-JH Extension wire harness.

Figure 25

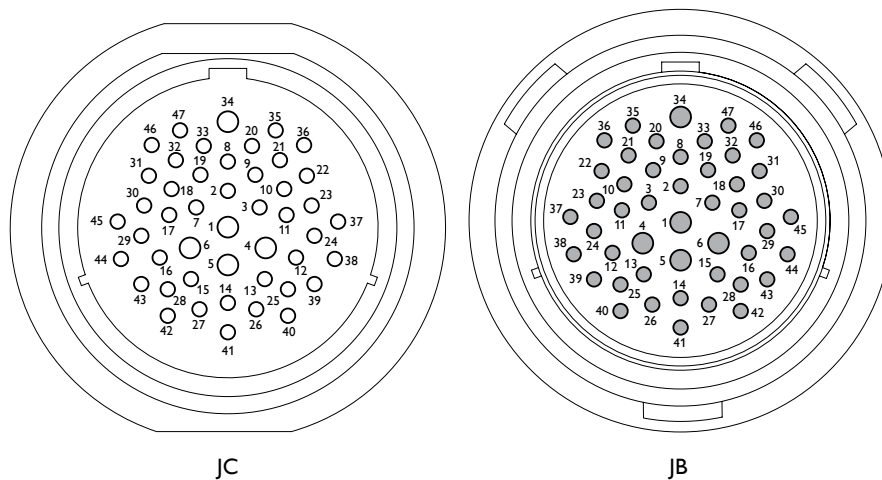

04\_250\_N

CONNECTORS OF THE EXTENSION WIRE HARNESS JB - JC, SEEN FROM THE COUPLING SIDE

The JC-JB wire harness comprises 47 lines, each connected to the terminal identified on both connectors by the same number.

To identify the functions served by the individual lines, refer to the electrical diagrams in Chapter 20.

## Installation

In order to drill holes on the area where the panel is to be mounted, refer to the dimensions indicated in Chapter 11.

## Operation of the panel

After completing the electrical connections and engine preparation, perform the tests required for the first start, as described in Chapter 18.

Verify the proper operation of the panel, proceeding as follows:

- ❑ Make sure that the "ENGINE ROOM / BRIDGE" switch of the Relay Box is in the "BRIDGE" position, then turn the key switch to the first position and verify that the instruments are powered and the Indications and Alarms Module runs the alarm test for about 5 seconds according to the procedures set out below.
- ❑ Once the test is complete, only the indications prescribed for the engine not running must remain lighted: e.g. "alternator charge" and "low oil pressure"; the analog instruments must provide values consistent with the relevant physical parameters.

## Testing the engine start function

Turn the key switch in the second position and release it quickly; the start function is fully controlled by the ECU and begins when the key is released.

## Checking indications

After starting the engine, verify whether the operating modes of the Indications and Alarms Module are similar to those set out below.

Using appropriate measuring instruments, verify the consistency of the indications provided by the analog instruments. Verify the indication of the panel revolution counter; comparing it with the one measured by a reference instrument; if the indication is different, proceed as described below.

## Testing the engine stop function

The engine is stopped and the panel is disabled by returning the key switch to the resting or zero position.

The panel has an engine stop push-button whose function is only enabled in versions where the engine stops as a result of the excitation of an actuator; i.e. engine versions requiring certification by Certification Bodies.

## Indications and Alarms Module

Figure 26

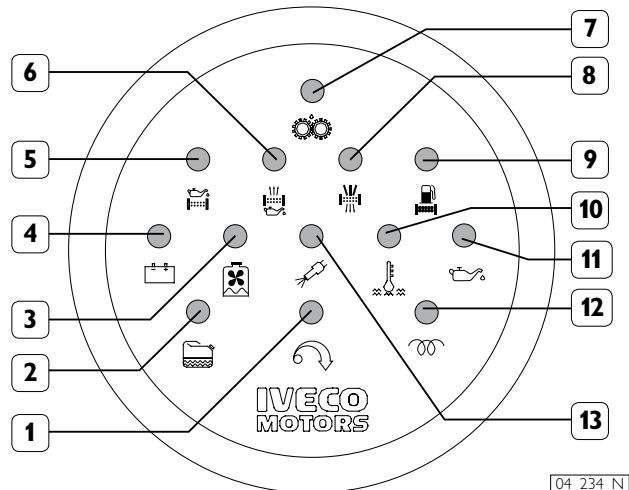

1. Engine overspeed (SSV) - 2. Presence of water in the fuel prefilter (SAC) - 3. Low engine coolant level (SBLA) - 4. Alternator anomaly (SS) - 5. Clogged oil filter (SIFO) - 6. Clogged blow-by filter (SIFB) - 7. Pre-lubrication in progress (SP) - 8. Clogged air filter (SIFA) - 9. Clogged fuel filter (SIFC) - 10. High coolant temperature (SATA) - 11. Low oil pressure (SBPO) - 12. Pre/post heating (SCP) - 13. EDC Malfunction (EDC).

The Indications and Alarm Module comprises the indicator lights and the electronic alarm interface, timing and storage circuit. It is programmed in such a way that when it is powered, all indicator lights are lighted, with the exception of those for "pre-lubrication", "pre-post heating" and "EDC" failure and a sound signal is emitted by the buzzer.

The buzzer may be silenced before the end of the test, acting on the appropriate control.

During the starting phase and for the subsequent 15 seconds, needed to stabilize the low oil pressure signal, all the module's functions are inhibited; once this time interval has elapsed, every alarm state detected by the sensors will cause the associated indicator to be lighted and the buzzer to be powered; the exceptions are the "pre-lubrication" and "pre-post heating" indicators, given only visually.

When a new alarm state is detected, the indicator light will flash to highlight the occurrence with respect to any others which may be ongoing at the time. When the sound alarm is shut off, the light indicator will remain lighted and the alarm will be stored until the engine is stopped.

The standard set-up of the V08 ENT M75, V08 ENT M11 and V08 ENT M12 provides for use of the indicators: SBLA, SIFA, SIFC, SIFO, EDC, SS.

## Revolution-counter calibration

Figure 27A

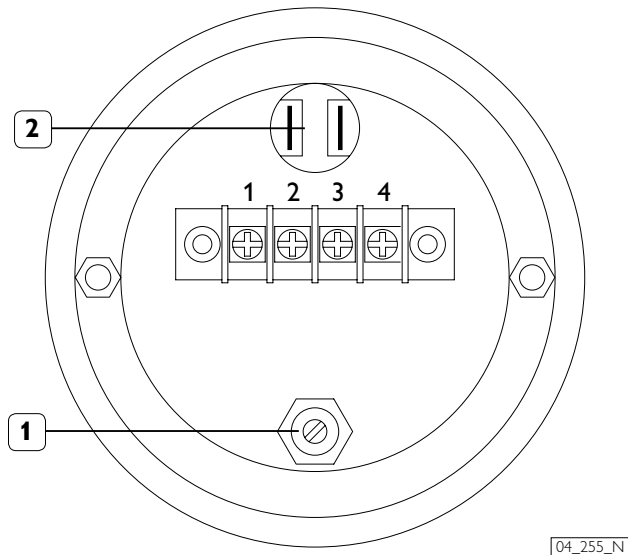

1. Adjustment screw - 2. Panel lighting lamp.

Verify the indication of the panel revolution counter by comparing it with the one measured with a reference instrument; if it differs, operate the adjustment screw (1), located in the rear part of the revolution counter, until consistency is achieved; repeat the operation for different engine rpms.

### Maintenance

Should it become necessary to replace a panel light, remove the lamp holder from the rear part of the instrument (see Figure 27A).

## Revolution-counter calibration

Figure 27B

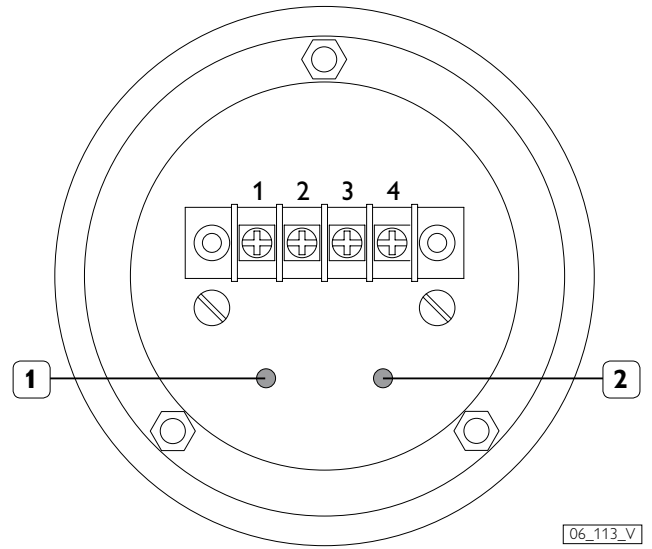

1. Calibration increasing button -  
2. Calibration decreasing button.

Verify the indication of the panel revolution counter by comparing it with the one measured with a reference instrument; if it differs, press the button 1 and 2 situated on the rear of the tachometer, until consistency is achieved; repeat the operation for different engine rpms.

### Maintenance

The board is illuminated by not-replaceable internal LEDs.



## 10. SECONDARY ANALOG INSTRUMENT PANEL

Figure 28

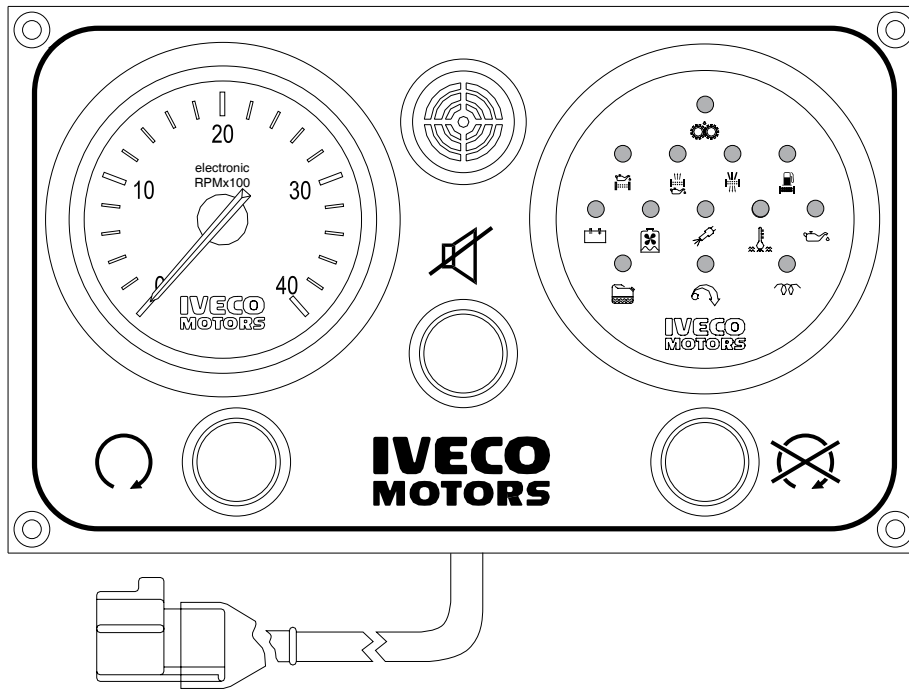

04\_240\_N

1. Connector for secondary panel wire harness (JH) - 2. Engine start push-button (CS) - 3. Revolution-counter (CG) -
4. Buzzer (SA) - 5. Indications and alarms module (MS) - 6. Engine stop push-button (AS) -
7. Sound alarm inhibition push-button (P1).

The connection is achieved by removing the cap on the JE connector of the main panel, and connecting the JE connector to the JH connector on the secondary panel, interposing the extension wire harness, available in 3, 5 and 7 metre-long versions (see Fig. 19). The JE-JH wire harness comprises 12 lines, each connected to the terminal identified on both connectors by the same number (see fig. 24).

Figure 29

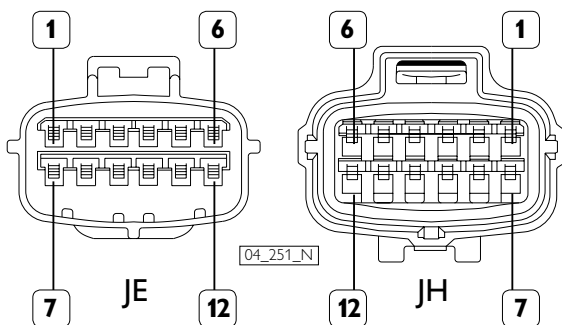

CONNECTORS OF THE JE-JH EXTENSION WIRE HARNESS, SEEN FROM THE COUPLING SIDE

### Installation

In order to drill holes on the area where the panel is to be mounted, refer to the dimensions indicated in Chapter 11.

### Operation of the secondary panel

After completing the electrical connection to the main panel and engine preparation, and performing the tests required for the first start (as described in Chapter 18), verify the proper operation of the panel, proceeding as follows:

- Make sure that the "ENGINE ROOM / BRIDGE" switch of the Relay Box is in the "BRIDGE" position, then turn the key switch to the first position, thus enabling the operation of both panels.
- Carry out the same tests for the secondary panel as were carried out for the main panel.
- Disable the secondary panel by bringing the key switch on the main panel to the resting or zero position.

### Testing the engine start and stop function.

With the panel enabled, press the green push-button until the engine starts, then release it; wait for engine rpm to stabilize before stopping it by pressing the red push-button. The starting and stopping operations can be performed several times and consecutively from the secondary panel

### Checking indications

Proceed in the same way as for the main panel.

### 11. DRILLING PLANS FOR ANALOG PANELS

Figure 30

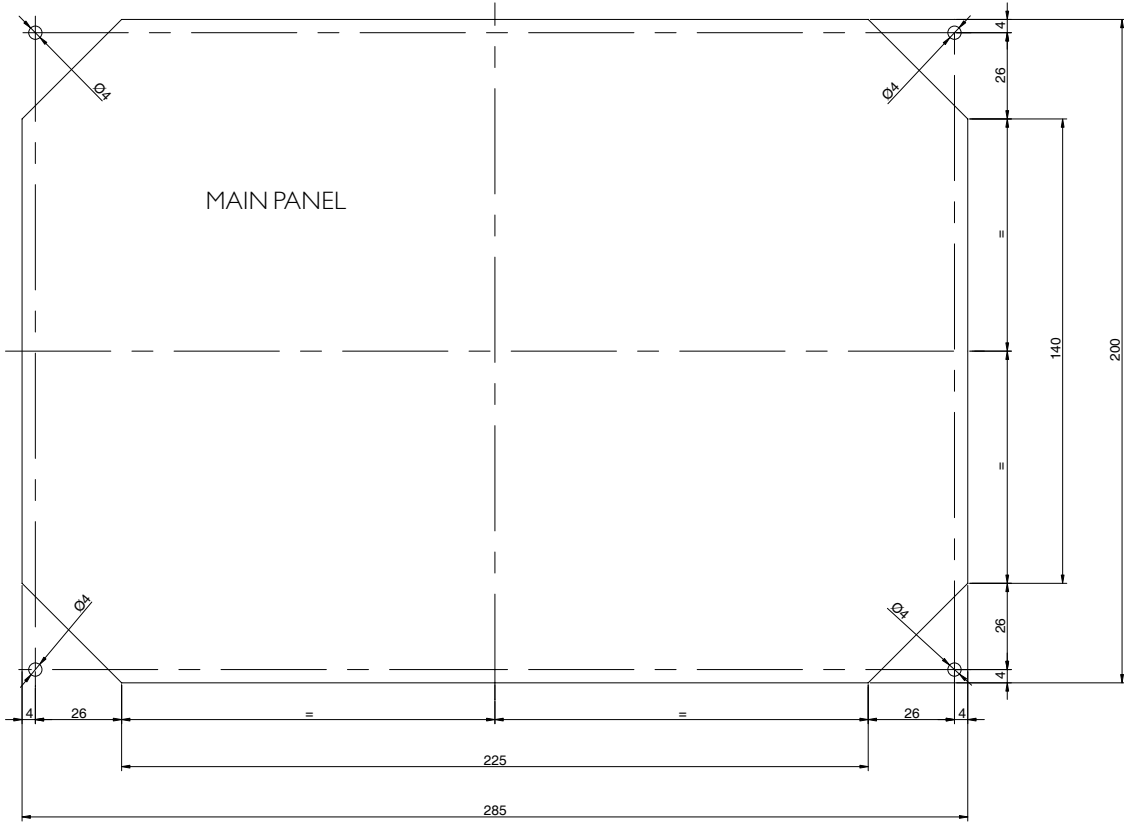

04\_022\_C

Dimension in millimetres.

Figure 31

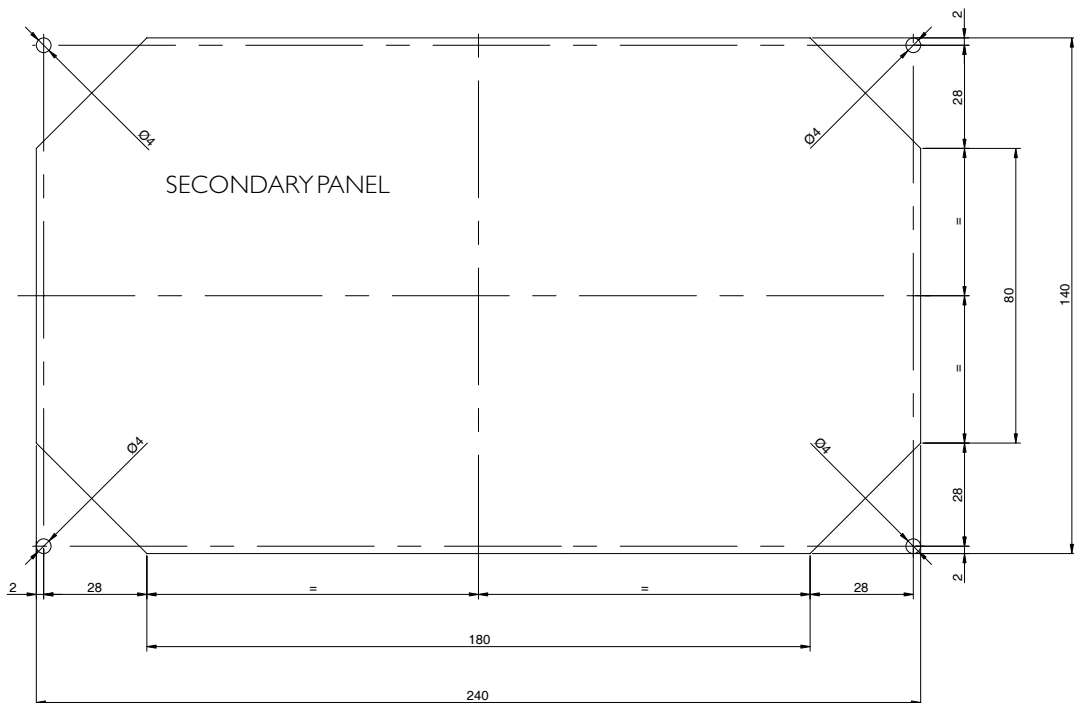

04\_023\_C

## 12. CUSTOMIZED INSTRUMENT PANEL

Using only the components of the panel that are not wired to allow the panel customization, they will have to be wired using the 10 metre long wire harness, set up at one end for coupling to the JB connector and at the opposite end with conductors with free terminals with identifying numbering on each wire. The conductors will have to be connected to the individual components as indicated in the electrical and wiring diagrams in Chapter 20.

### CAUTION

To assure the functionality of the safeties pertaining to the engine start/stop commands from the instrument panel or engine room, it is mandatory to wire the key switch strictly as shown in the electrical diagrams in Chapter 20.

The wiring details of the indications and alarms module alone are provided below; indications for IVECO MOTORS indicator instruments are shown in the related wiring diagrams in Chapter 20.

### JD Connector for indications and alarms module

Figure 34

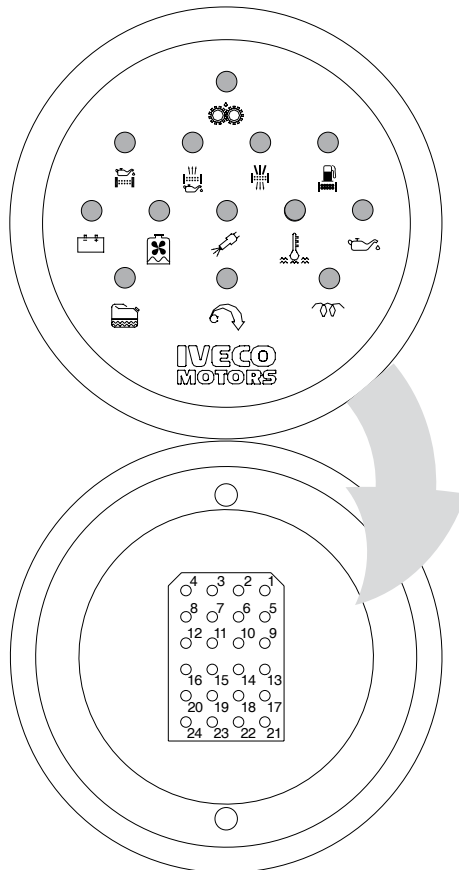

05\_034\_C

VIEW FROM THE SIDE INTEGRATED IN THE REAR PART OF THE MODULE

Figure 35

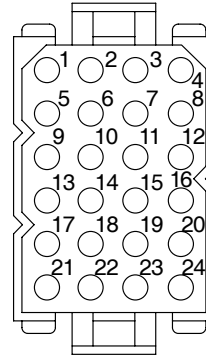

04\_241\_N

VIEW FROM THE TERMINAL SIDE OF THE COUPLING SIDE WIRING

connector	TRIDENT / ITT CANNON	part TST 24PA00
terminal	female	part 192990-0050
lid	rear	part TST24AH0

JD connects the indications and alarms module to the electrical system of the engine (sensors, power supply, etc.).

The terminal part of the wire harness, supplied with the module, must be completed using female terminals, as described in the electrical diagram of Chapter 20.

For standard-equipped engines, to have the essential indications available, the following ways must be wired: 1, 3, 7, 8, 9, 10, 11, 13, 14, 15, 16, 17, 18, 19 with the female terminals supplied as standard equipment.

## Functions of the JD terminals

PIN	Description	Electric level	
		OFF Indication	ON Indication
1	Module power supply		Positive (+B)
2	Not connected		-
3	EDC Fault indication	High (+B)	Low (ground)
4	Not connected		-
5	Pre-heating indication	High (+B)	Low (ground)
6	Pre-lubrication indication	Open circuit	High (+B)
7	Engine start	Power supply positive (+B) while starting	
8	Buzzer inhibition	Negative (ground) during the request	
9	Module power supply	Negative (ground)	
10	Sound alarm power supply	Negative (ground) during the emission of sound	
11	Clogged oil filter indication	Open circuit	Low (ground)
12	Clogged oil vapour filter indication (not applicable)	Open circuit	Low (ground)
13	Clogged air filter indication	Open circuit	Low (ground)
14	Clogged fuel filter indication	Low (ground)	Open circuit
15	Alternator fault indication	High (+B)	Low (1 to 3 V)
16	Low engine coolant level indication	Open circuit	Low (ground)
17	High coolant temperature indication	Open circuit	Low (ground)
18	Low engine oil pressure indication	Open circuit	Low (ground)
19	Presence of water in fuel indication	Open circuit	Low (ground)
20	Overloaded or runaway engine indication	Open circuit	High (+B)
21	Not connected		-
22	Not connected		-
23	Reception of data from main panel	NMEA communication protocol (0 to 5 V)	
24	Transmission of data to secondary panel	NMEA communication protocol (0 to 5 V)	

### CAUTION

To assure the utmost reliability and safety while underway, all installations must be provided with the following alarm indications:

- (EDC) EDC failure
- (SATA) high coolant temperature
- (SBPO) low oil pressure

It is also recommended that the following indications are present:

- (SAC) presence of water in the fuel prefilter
- (SIFA) clogged air filter
- (SS) alternator fault

### 13. SENSORS FOR DETECTION AND INSTRUMENT PANEL SIGNALLING

#### Coolant temperature sensor

Figure 36

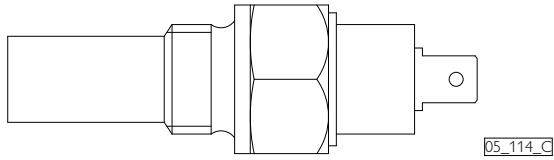

Resistor with negative temperature coefficient, providing the signal for analog temperature indication.

Operating voltage	from 6 to 24 V
Calibration range	from 0° to 120 °C
Resistance value at 90°C	51.2 ± 4.3 Ω
Electrical poles	isolated

#### Low level coolant sensor

Figure 37

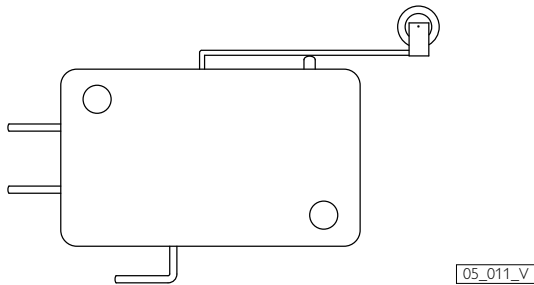

Microswitch sensor controlled by the float of the coolant tank.

Operating voltage:	from 6 to 24 V
Condition for high level	open
Maximum current	2 A not inductive
Electrical poles	isolated

#### Oil pressure sensor

Figure 38

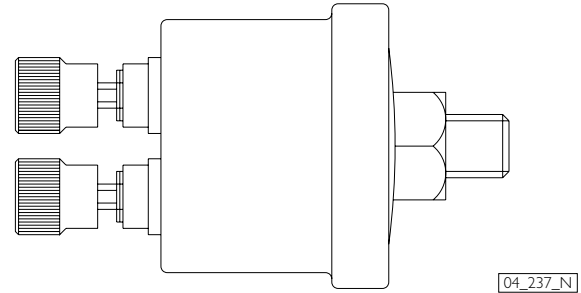

Rheostat component providing the signal for the analog indication of pressure.

Operating voltage	from 6 to 24 V
Calibration range	from 0 to 10 bar
Resistance value at 0 bar	10 Ω +3/-5 Ω
Resistance value at 2 bar	52 ± 4 Ω
Resistance value at 4 bar	88 ± 4 Ω
Resistance value at 6 bar	124 ± 5 Ω
Maximum value of resistance	184 Ω
Operating temperature	from - 25 to 100 °C
Electrical poles	isolated

### Clogged air filter sensor

Figure 40

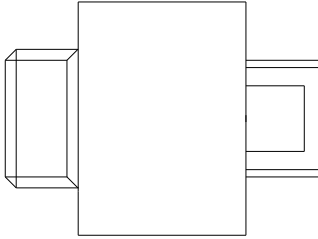

04\_238\_N

Vacuum switch, providing the signal for the clogged air filter alarm indicator.

Operating voltage:	from 6 to 24 V
Condition at ambient pressure	normally open
Closing vacuum:	$\geq -52$ mbar
Operating temperature:	-20 / +80 °C
Maximum current	0.1 A (not inductive)
Electrical poles	isolated

### Clogged oil filter sensor

Figure 41

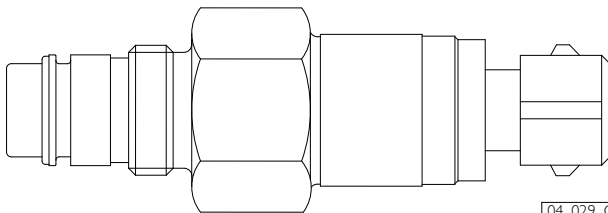

04\_029\_C

Differential pressure switch, providing the signal for the related indicator when pressure difference between inlet / outlet oil filter is more then a limit value.

Operating voltage:	from 6 to 24 V
Condition at ambient pressure	normally open
Closing pressure:	$2.4 \pm 0.3$ bar
Opening pressure:	$1.8 \pm 0.3$ bar
Maximum current	3 A (not inductive)
Electrical poles	isolated

### Clogged fuel filter sensor

Figure 42

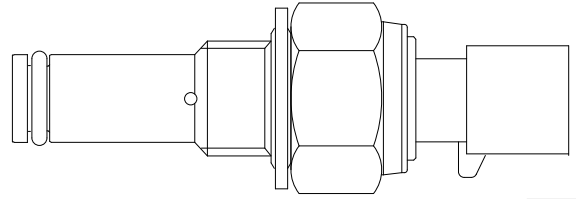

04\_030\_C

Pressure switch, providing the signal for the related indicator, when the pressure at the fuel filter inlet is too high.

Operating voltage:	from 6 to 24 V
Condition at ambient pressure	normally closed
Opening pressure:	$1.5 \pm 0.1$ bar
Maximum current	0.1 A (not inductive)
Electrical poles	isolated

### Exhaust gas temperature sensor

Figure 43

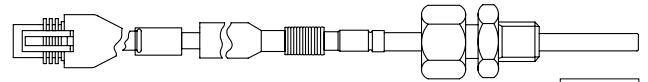

04\_260\_N

NiCr-Ni thermocouple sensor with insulated poles, providing the signal for the analog indication of exhaust gas temperature.

Temperature	Voltage
°C	mV
100	4.10
200	8.13
300	12.21
400	16.40
500	20.65
600	24.91
700	29.14
800	33.30
900	37.36

## Sensor to detect water in fuel

Figure 44

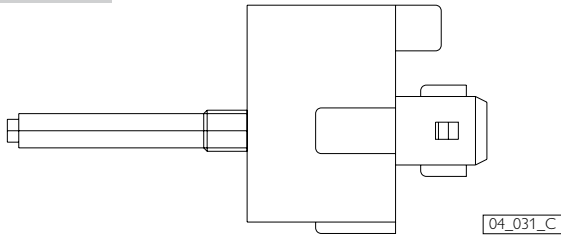

Fuel resistivity sensor, integrated with the control and amplification electronic circuit, providing the signal for the indicator of the presence of water in the fuel.

Operating voltage	from 12 to 24 V
Condition in the absence of water	open circuit
Closed condition	resistance of the liquid $\leq 1 \text{ M}\Omega$
Operating temperature	from -20 to +80 °C

### Connections of the sensor detecting the presence of water in fuel

Figure 45

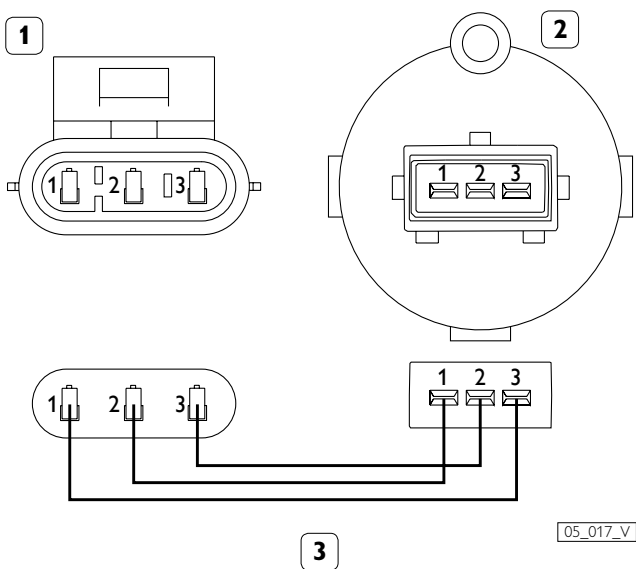

1. M Connector of the engine wire harness -
2. Sensor detecting the presence of water in the fuel -
3. Wiring harness (outfitter's responsibility).

The three pole connection between the sensor for detecting the presence of water in the fuel and the engine wire harness must be produced by the outfitter according to the position of the fuel prefilter in the boat.

Connection to the engine wire harness requires a METRI-PACK150 three-pole connector with three male terminals; connection to the sensor requires a JUNIOR TIMER three-pole connector with three female terminals.

## CAUTION

In order to enable the proper working of the sensor to detect water in fuel, the pre-filter support needs to be electrically connected to the negative battery terminal.

In the engine models which use parts with insulated poles it is necessary to electrically insulate the prefilter support from the boat mass and then connect the support with the negative battery terminal.

## Neutral gear sensor

## CAUTION

When neutral gear sensor is installed remember to connect it to GN connector.

In installation without sensor, do not remove the cap of the GN connector to avoid compromising start engine function.



## 14. PREPARING THE ENGINE FOR FIRST START-UP

1. Drain the residual 30/M protective oil from the sump.
2. Pour into the lubricating loop only lubricating oil of the type and in the quantities set out in the Refilling Table.
3. Drain the CFB protective liquid from the fuel loop, completing the operations as indicated under item 3. of Chapter 19.
4. Remove the caps and/or seals from the engine intake, exhaust, aeration and venting ports, restoring normal conditions of use. Connect the inlet of the turbocharger to the air filter.
5. Connect the fuel loops to the boat tank, completing the operations set out in item 4. of Chapter 19. During filling operations, connect the pipe returning fuel to the tank to a collecting container; to prevent residues of CFB protective liquid from ending up into the boat tank.
6. Verify and refill engine coolant as prescribed.
7. Remove from the engine the labels with the inscription "ENGINE WITHOUT OIL".

## 15. TESTS BEFORE THE FIRST START-UP

Although they are extremely important, "common sense" checks such as the exposure of sensitive parts (plastics, wire harness, electronic units, etc. ...) to heat, and those that for years have characterized the quality of the work performed in the yard, are not mentioned herein.

Tests of the proper operation of the engine and the components of the electronic control system may be performed rapidly and with the utmost reliability using specific diagnostic tools, available from IVECO MOTORS Technical Assistance Centres.

### Fuel tank suction

Verify the fuel suction at the maximum allowed longitudinal and transverse inclination, with the residual quantity of fuel considered "RESERVE", such as to cause the reserve indicator light to be permanently lighted.

### Throttle lever position sensor

In the positions of minimum and maximum travel, verify the correlation between the position of the throttle control valve on the bridge and the position of the sensor rod.

### Instruments and control panel

Verify the efficiency of all light indicators, as described in the related Chapters.



## RPM control

To allow easily to control engine RPM from the "engine room", a simultaneous acceleration/deceleration function (RPM+/RPM-), active only when the switch (1) is in the "ENGINE ROOM" position, and the switch (2) is in IGNITION position.

### Acceleration (RPM +)

If, the engine is running, and RPM+ / RPM- push-button (4) is held down in the "RPM+" position, then engine rpm are progressively increased. The increase ends when the push-button is released, allowing the engine to run at the desired rpm.

### Deceleration (RPM -)

If the engine is running, and RPM+ / RPM- push-button is held down in the "RPM-" position, a progressive reduction in rpm is obtained. The reduction ends when the push-button is released, allowing the engine to run at the desired rpm.

The set out engine speed will be kept until the next engine shut-off.

The engine shut-off resets every previous configuration.

### NOTE

The effect of the RPM + e RPM - controls varies according to the duration of the operation:

it is achieved a very slow variation during the first 3 seconds; continuing the operation, the regulation becomes much more effective and enables to complete the full range of the engine speed in a overall time of about 20 seconds.

## CAUTION

**Never operate the "BRIDGE - ENGINE ROOM" switch when the engine is running.**

Once the first start-up phase is complete, verify that:

- There are no liquid leaks from the coolant loop pipeline junction hoses.
- There are no exhaust gas leaks in the hull.
- In order to carry out the cooling system degassing, do as follows:

Figure 45

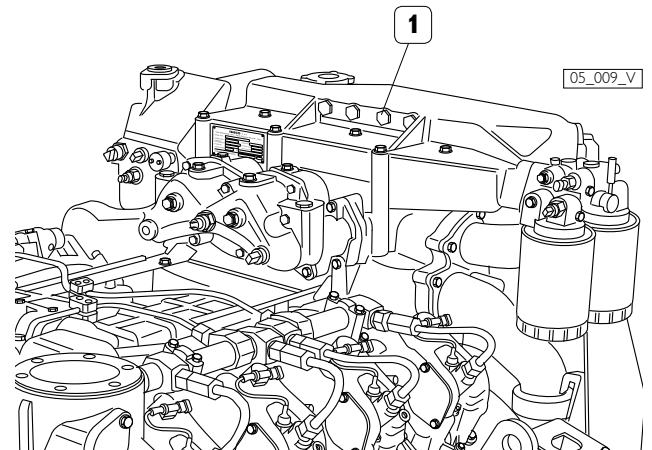

1. Venting screw.

Stop the engine, then loose the venting screw (1) carefully to degas the expansion tank. When the operation is completed, tighten the screw to the prescribed torque, start the engine and keep it up for a few minutes. Stop the engine and verify the coolant level again, fill it up, if necessary.

Make sure that the coolant that flows out is not dispersed in the environment.

- Complete the instrument panel operation tests as described in the related Chapters.
- Verify that the power supply voltage across the battery, after about 15 minutes with the engine running, is no less than about 26 V.
- Stop the engine and delete any "errors" which may have been stored in the injection system ECU during the stabilization phases. The error deletion can be carried out by the diagnostic instrument IVECO SERVICE TOOL.

## 17. EDC ECU INDICATION LIGHTS

### CHECK Indication light

Figure 45

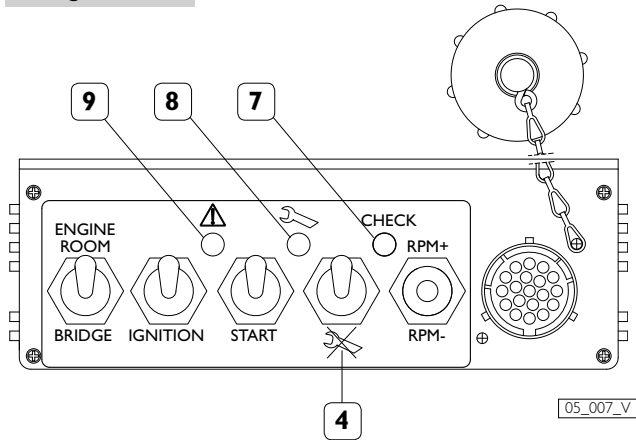

- 4. Reset button of the "maintenance alarm" -
- 7. Blink code emission LED (EDC) - 8. Signalling LED of maintenance interval expiration - 9. Signalling LED for fault engine operating parameters (WARNING).

The ECU continuously monitors its own operating conditions, as well as of the engine and of components connected to it with complex auto-diagnosis routines.

The identification of anomalies causes:

- the anomaly data storage in the ECU.
- the blinking lighting of the fault indication light EDC on the instrument panel.
- the lighting of the green indication light CHECK (7) on the relay box.

The blinking lighting of the EDC fault indication light has the purpose to inform about a detected anomaly, whose

identification is taken "reading" the blink code of the CHECK indication light.

(Indications for decoding codes are in the following chapter).

The code emission happens automatically and sequentially when the anomalies are detected; the sum of the current anomaly code is designated "list".

Each single code is organized in 3-digit numerical blocks with a fixed lighting duration equal to 0.6 s.

The pauses (switch-off time) have a different duration to distinguish the given type of information:

pause between blinking of the same digit	0.36 s
pause between different digits of the same code	1.5 s
pause between different codes of the same list	3 s
pause between consecutive lists	6 s

The emission is continuative, i.e. the code list is repeated consecutively with the same order; a 6-second pause separates the list repetitions.

#### NOTE

Only the codes of the current anomalies are returned; a temporary anomaly causes the emission of the associated code for the whole period the anomaly is present. The emission code stops when the operating conditions are restored, while the data concerning the anomaly are stored in the failure memory of the ECU.

The stored information are able to be decoded and erasable by the IVECO SERVICE TOOL.

Example of emission of the anomaly codes:

Figure 45

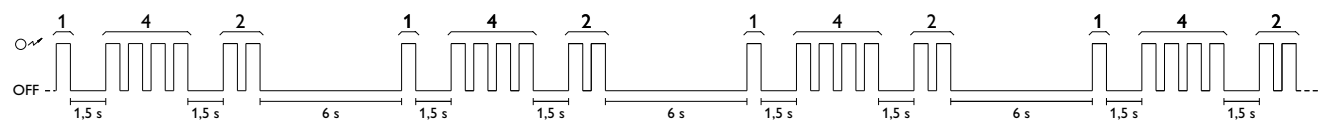

EMISSION CODE 142

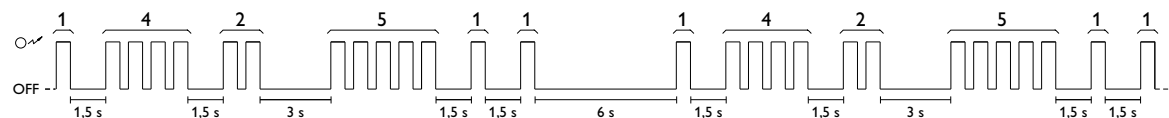

EMISSION CODES 142 AND 511

05\_090\_V

### **WARNING Indication light**

The ECU carries out a control activity on the operating conditions through the analysis of the detected operating parameters; it evaluates the behaviour of the single signals emitted by the sensors and classifies the situation, according to predetermined threshold, activating the red indication light (9 figure 45).

#### **Blinking indication light - warning level:**

Lighting cycle of 0.6 s and pause of 0.24 s.

It indicates that the value is slightly above the normal threshold; the user of the vessel does not notice any difference in the engine behaviour.

#### **Indication light constantly On - derating level:**

It indicates that the value is significantly above the normal threshold; the maximum power of the engine is reduced to protect its intactness. The user of the vessel can notice the reduction of the power of the engine.

#### **NOTES**

Only the current anomalies enable the behaviour specified above; a temporary anomaly causes the lighting of the indication light, according to the modalities illustrated, for the whole period the anomaly is present. The emission code stops when the operating conditions are restored, while the data concerning the anomaly are stored in the failure memory of the ECU.

The signalling is available on the relay box only, and does not involve any other indications on the instrument panel.

The stored information are able to be decoded and erasable by the IVECO SERVICE TOOL.

### **SHUTDOWN (preliminary)**

When the most critical thresholds exceed their normal values, it can be enabled the forced engine shutdown.

The next time the engine is started, if the normal operation are restored, there will not be any lighting signalling, while the data concerning the anomaly are stored in the failure memory of the ECU.

Parameter list that can cause warning, derating or shutdown conditions:

- Engine coolant high temperature
- Intake air high temperature
- Engine oil low pressure
- Engine overspeed
- Fuel high temperature
- Engine oil low temperature
- Engine oil high temperature
- Rail low pressure
- Rail high pressure
- Loss on the high pressure fuel line
- Intake air high pressure
- Intake air low pressure
- Power supply voltage

### **Signalling maintenance interval expiration**

The lighting of the indication lights MAINTENANCE (8 figure 45), caused by the ECU, indicates the need to perform the periodical lubricating oil replacement.

When the operation is performed, it is necessary to press the button (4 figure 45) to restore the counter and begin a new operating cycle. The signalling is available on the relay box only, and does not involve any other signalling on the instrument panel.

**Blink code table (temporary list)**

Component	Anomaly	Code
Cylinder 1 electro-injector	open circuit/short circuit	111
Cylinder 2 electro-injector	open circuit/short circuit	112
Cylinder 3 electro-injector	open circuit/short circuit	113
Cylinder 4 electro-injector	open circuit/short circuit	114
Cylinder 5 electro-injector	open circuit/short circuit	115
Cylinder 6 electro-injector	open circuit/short circuit	116
Cylinder 7 electro-injector	open circuit/short circuit	117
Cylinder 8 electro-injector	open circuit/short circuit	118
Air intake temperature sensor	open circuit/short circuit to +B or to ground	133
Air intake pressure sensor	open circuit/short circuit to +B or to ground	135
Flywheel sensor	anomalous or missing signal	141
Timing system sensor	anomalous or missing signal	142
Timing system sensor	irregular mechanical behaviour	142
Relay for engine start	open circuit/short circuit	145
Atmospheric pressure sensor	open circuit/short circuit to +B or to ground	152
Throttle position sensor	anomalous or missing signal	154
Engine oil temperature sensor	open circuit/short circuit to +B or to ground	156
Engine oil pressure sensor	open circuit/short circuit to +B or to ground	157
Rail pressure sensor	open circuit/short circuit to +B or to ground	159
Pressure limiter valve	open circuit/short circuit	162
Pressure limiter valve	irregular mechanic behaviour	162
Fuel temperature sensor	open circuit/short circuit to +B or to ground	165
Engine temperature sensor	open circuit/short circuit to +B or to ground	168
Relay for pre-post heating resistor	open circuit/short circuit	178
Engine high temperature indication light	open circuit/short circuit	191
Engine oil low pressure indication light	open circuit/short circuit	192
Throttle control from relay box	anomalous or missing signal	195
Battery voltage	insufficient or excessive value	511
Power supply voltage 5 V connector J2	insufficient or excessive value	516
Power supply voltage 8 V	insufficient or excessive value	517
Indication light Warning	open circuit/short circuit	525
Indication light Maintenance	open circuit/short circuit	526
Power supply voltage 5 V connector J1	insufficient or excessive value	599

## 18. UNDERWAY CHECKS

### ECU Temperature

Verify that the temperature of the surface of the electronic engine control unit, after 30 minutes underway at full engine power, is less than +70°C.

### Engine compartment vacuum

Verify that value of ambient air pressure in the engine room with the engine(s) at full load and maximum power output complies with the value specified herein.

### Combustion air temperature

Verify that the temperature in the engine room, after 30 minutes underway at full engine power, does not exceed 45°C (V08 ENT M75) or 50°C (V08 ENT M11 e V08 ENT M12) and, in any case, does not exceed the value of external temperature by more than 15°C.

### Exhaust back-pressure

Verify that the value of back-pressure present at the inlet of the exhaust gas conduit, with the engine(s) at full load and maximum power output, complies with the value specified herein.

### Exhaust temperature

Verify that the temperature of the exhaust gases under maximum engine power output conditions is close to the prescribed value; to determine the propeller power absorption curve, it will also be possible to obtain from the ECU parameters the fuel injection values by using the IVECO MOTORS tool.

### Fuel temperature

Verify that the temperature of the fuel in the low pressure line, while underway at full power and with a stable quantity of fuel in reserve, does not exceed 70°C. A higher value would entail a reduction in engine performance. If the tendency to reach the maximum allowed temperature is noted, install a heat exchanger for the fuel.

### Pressure in the fuel supply line

To assure the regular operation of the engine and the reliability of the components of the fuel supply and injection system, you need to verify that:

- vacuum in the fuel oil supply line to the low pressure pump is less than 0.5 bar relative (5000 mmH<sub>2</sub>O);  
pressure in the fuel oil supply line to the low pressure pump is less than 0.5 bar relative (5000 mmH<sub>2</sub>O);
- pressure in the fuel oil return line to the tank is less than 0.2 bar relative (2000 mmH<sub>2</sub>O).

Measures are carried out inserting a "T" junction near the fuel inlet and outlet, taking care to avoid any air suction. Values are read at variable rpm, from idle to maximum, at 200 rpm intervals.

If there are any symptoms indicating the possible presence of air in the fuel supply line, a check may be made by inserting a clear tube, arranged as an inverted U, before the engine inlet junction.

## 19. PREPARING THE ENGINE FOR LONG IDLE PERIODS

To prevent oxidation to the internal parts of the engine and to some components of the injection system, if idle periods exceeding two months are expected, the engine needs to be prepared with **six-month periodicity**, proceeding as follows:

1. Drain the lubricating oil from the sump, after heating the engine.
2. Pour 30/M protective oil (alternatively, oil conforming to MIL 2160B Type 2 specifications) into the engine to the "minimum" level marked on the dipstick.  
  
Start the engine and let it run for about 5 minutes.
3. Drain the fuel from the injection line and from the filters, taking care to prevent the fuel from coming in contact with the alternator's belt.
4. Connect the fuel line to a tank containing CFB protective liquid (ISO 4113) and assist the inflow of the liquid by pressurizing the line and turning the engine over for about 2 minutes, after excluding the operation of the injection system. The required operation may be carried out by directly polarizing the terminal 50 of the electric starter motor with positive voltage 24 V, using a conductor prepared for the occasion.
5. Nebulize 30/M protective oil at the rate of about 100 g (10 g per litre of displacement) in both turbochargers, while the engine is turning over as described above.
6. Close with suitable stoppers or seal with adhesive tape all engine intake, exhaust, aeration and venting ports.
7. Drain the residual 30/M protective oil from the sump; it may be re-used for 2 more engine preparation operations.
8. Apply tags with the inscription "ENGINE WITHOUT OIL" on the engine and onboard panel.
9. Drain the coolant, if it has not been mixed with anti-freeze and corrosion inhibiting agents, affixing tags to indicate that the operation has been carried out.

If external parts of the engine are to be protected, spray protective liquid OVER 19 AR onto unpainted metal parts, such as flywheel, pulleys and others; avoid spraying belts, connector cables and electrical equipment.





## 20. ELECTRIC DIAGRAMS

### Wiring diagram key

General condition for the preparation and interpretation of wiring diagrams

- Key switch open
- Engine not running
- Liquids at efficient levels and pressures

Figure 48

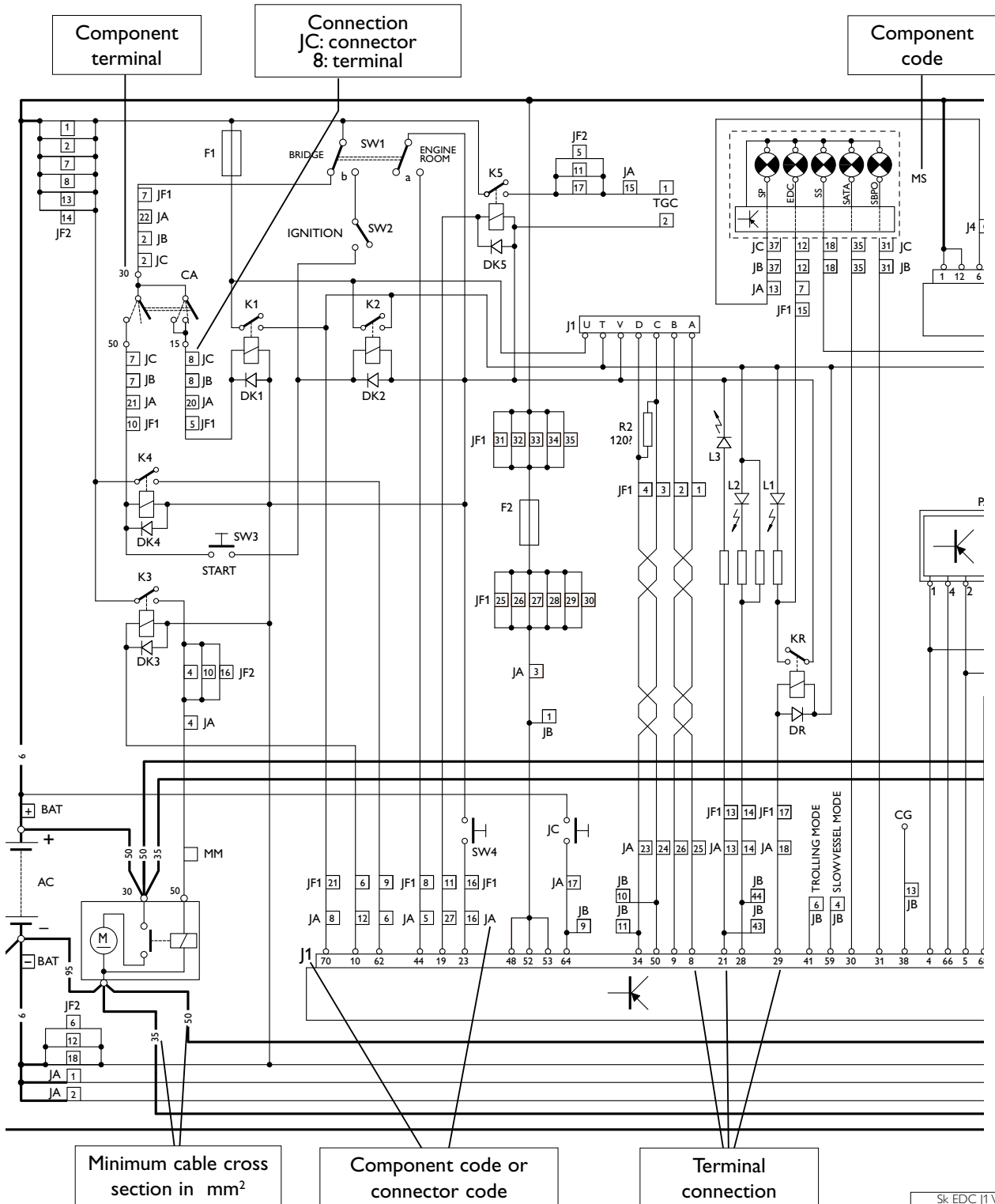

## Electrical equipment component code

A	fuel temperature sensor for EDC
AC	battery
AP	atmospheric pressure sensor
AQ	engine shut-off push-button on main panel
AS	engine shut-off push-button on secondary panel
B	crankshaft sensor for EDC
C	camshaft sensor
CA	key switch
CS	engine start push-button on secondary panel
E1/E8	electro-injectors
F	engine coolant temperature sensor for EDC
GG	alternator
GH	grid heater power relay
GN	neutral gear sensor
H	combustion air pressure sensor for EDC
J	low coolant level sensor (for alarm)
JC	emergency shut-off push-button (optional, installer's responsibility)
JF1, JF2	relay box
JG	lubrication oil transfer electrical pump control unit
JG1	pre-lubrication electrical pump control unit
K, K1	clogged air filter sensors (for alarm)
L	instrument panel light switch
L1	EDC blink code emission green LED (on relay box panel)
L2	signalling red LED for fault engine operating parameters (WARNING) (on relay box panel)
L3	signalling yellow LED of maintenance interval expiration (on relay box panel)
M	sensor for detecting the presence of water in the fuel prefilter (for alarm)
MM	electric starter motor
MS	IVECO MOTORS indications and alarms module
O, O1	exhaust gas temperature sensors (for gauge)
P	combustion air temperature sensor for EDC
P1	sound alarm inhibition push-button
PA	throttle position sensor
PF	rail pressure control solenoid valve
PH	grid heater
PO	lubrication oil transfer electrical pump
POP	pre-lubrication electrical pump
PR	rail pressure sensor
QP	main analog instrument panel
QS	secondary analog instrument panel
S	oil temperature sensor for EDC
SA	buzzer
SI	gear oil temperature sensor
S1	engine oil temperature sensor (for gauge)
SW1	engine control selector from bridge or engine room (on relay box panel)
SW2	power supply switch of the engine electric circuits (on relay box panel)
SW3	start button from engine room (on relay box panel)
SW4	reset button of the "maintenance alarm" (on relay box panel)
SW5	manual throttle control in engine room (on relay box panel)
T	coolant temperature sensor (for gauge)
TGC	power relay for electric starter motor insulation (provision)
U	clogged oil filter sensor (for alarm)
V	engine oil pressure sensor for EDC
VI	gear oil pressure sensor
V1	engine oil pressure sensor (for gauge)
WI	low gear oil pressure sensor
X	clogged blow-by filter sensor (for alarm)
Z	clogged fuel filter sensor (for alarm)
85150	ECU of the EDC system

(continues on next page)

**Connectors**

J1	on the relay box panel for external diagnostic tool
J1	70-pole EDC - boat components connections
J2	70-pole EDC - engine components connections
J3	lubrication oil transfer electrical pump
J4	pre-lubrication electrical pump
JA	connection between engine wiring and interface wire harness
JB ON ENGINE WIRE HARNESS	
	ready for connection to the main analog instrument panel
JC ON MAIN ANALOG INSTRUMENT PANEL	
	ready for connection to the engine wire harness
JD	IVECO MOTORS indications and alarms module
JE ON MAIN ANALOG INSTRUMENT PANEL	
	ready for connection to the secondary analog instrument panel
JF1,JF2	relay box
JH ON SECONDARY ANALOG INSTRUMENT PANEL	
	ready for connection to the main analog instrument panel

**Indicator lights**

EDC	EDC malfunction
SAC	presence of water in fuel prefilter
SATA	coolant high temperature
SBLA	low coolant level
SBPO	low oil pressure
SCP	pre-post heating
SIFA	clogged air filter
SIFB	clogged oil vapour filter
SIFC	clogged fuel filter
SIFO	clogged oil filter
SIM	expired programmed maintenance interval
SP	pre-lubrication
SS	alternator fault
SSV	engine overspeed

**Gauges**

CG	revolution-counter
Ml	gear box oil pressure
MO	engine oil pressure
TA	engine temperature
TI	gear box oil temperature
TS	exhaust gas temperature
V	voltmeter

**Relays contained in the relay box**

K1	key switch electric discharge
K2	IGNITION switch electric discharge
K3	power supply to terminal 50 of the electric starter motor
K4	start request signal, from key switch to EDC electronic unit
K5	TGC control ready
KR	EDC blink code emission LED control

**Fuses contained in the relay box**

F1- F2	self restoring (not replaceable)
--------	----------------------------------

# EDC connector J1

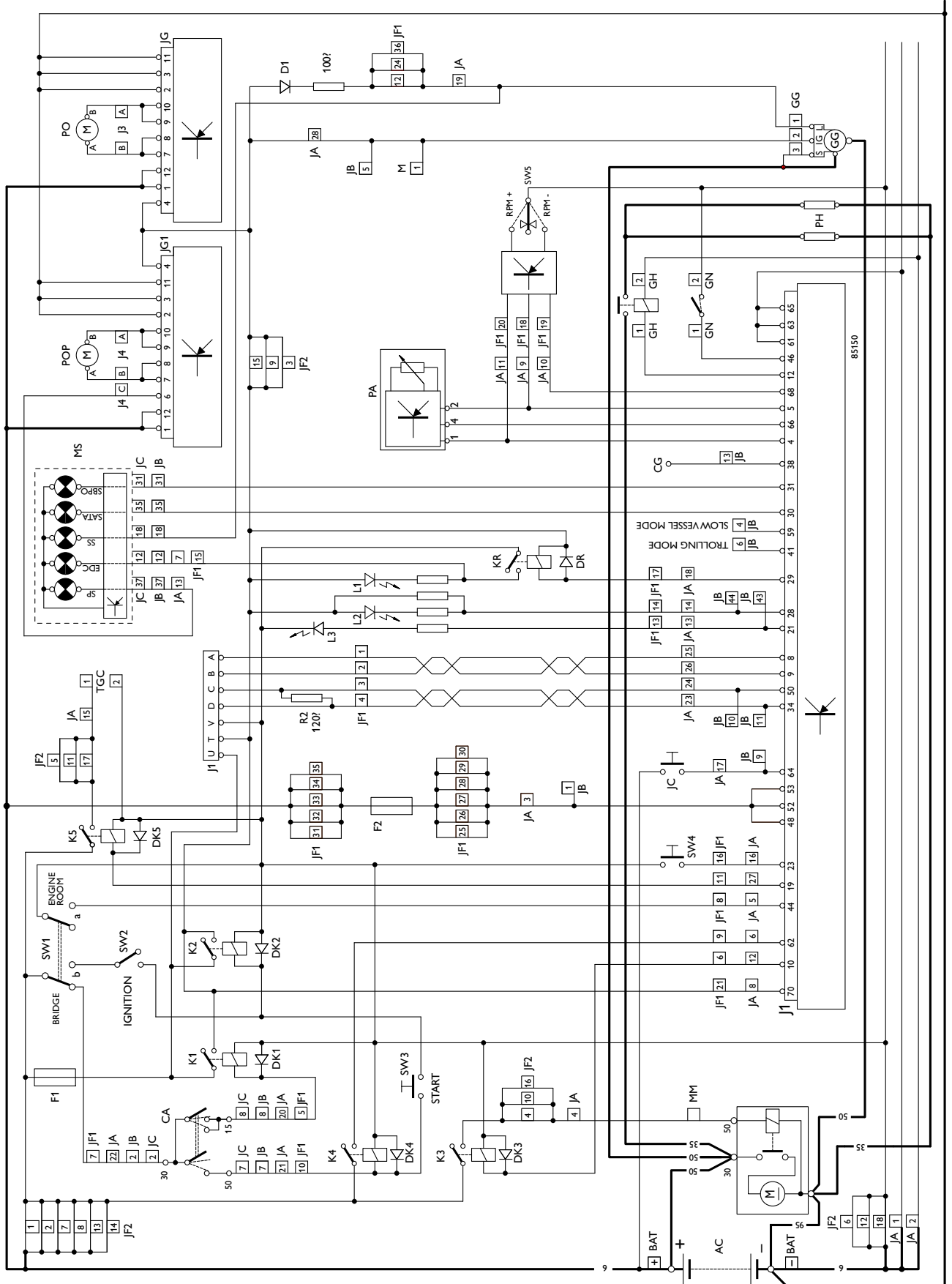

### EDC connector J2

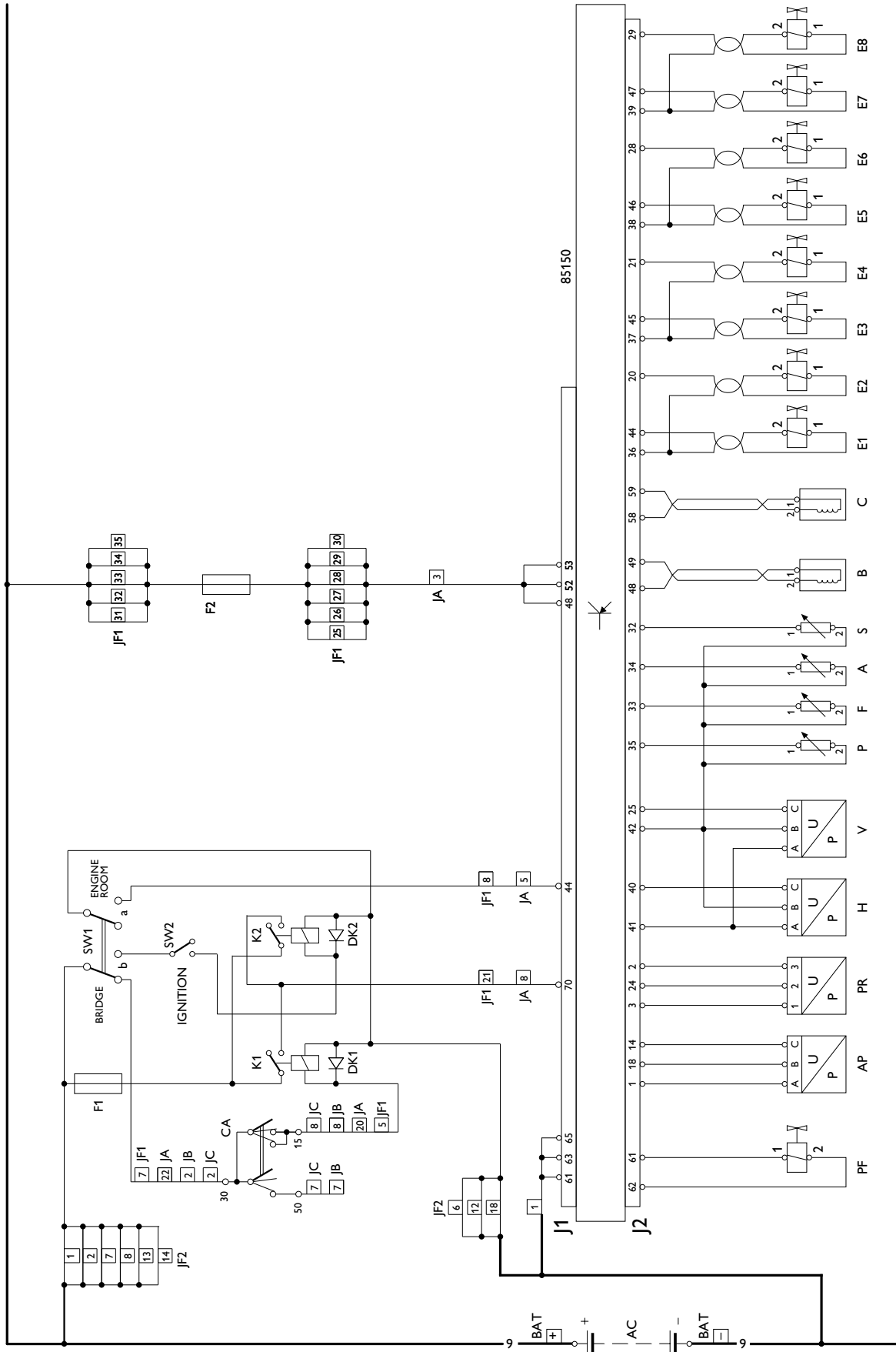

### Main analog instrument panel

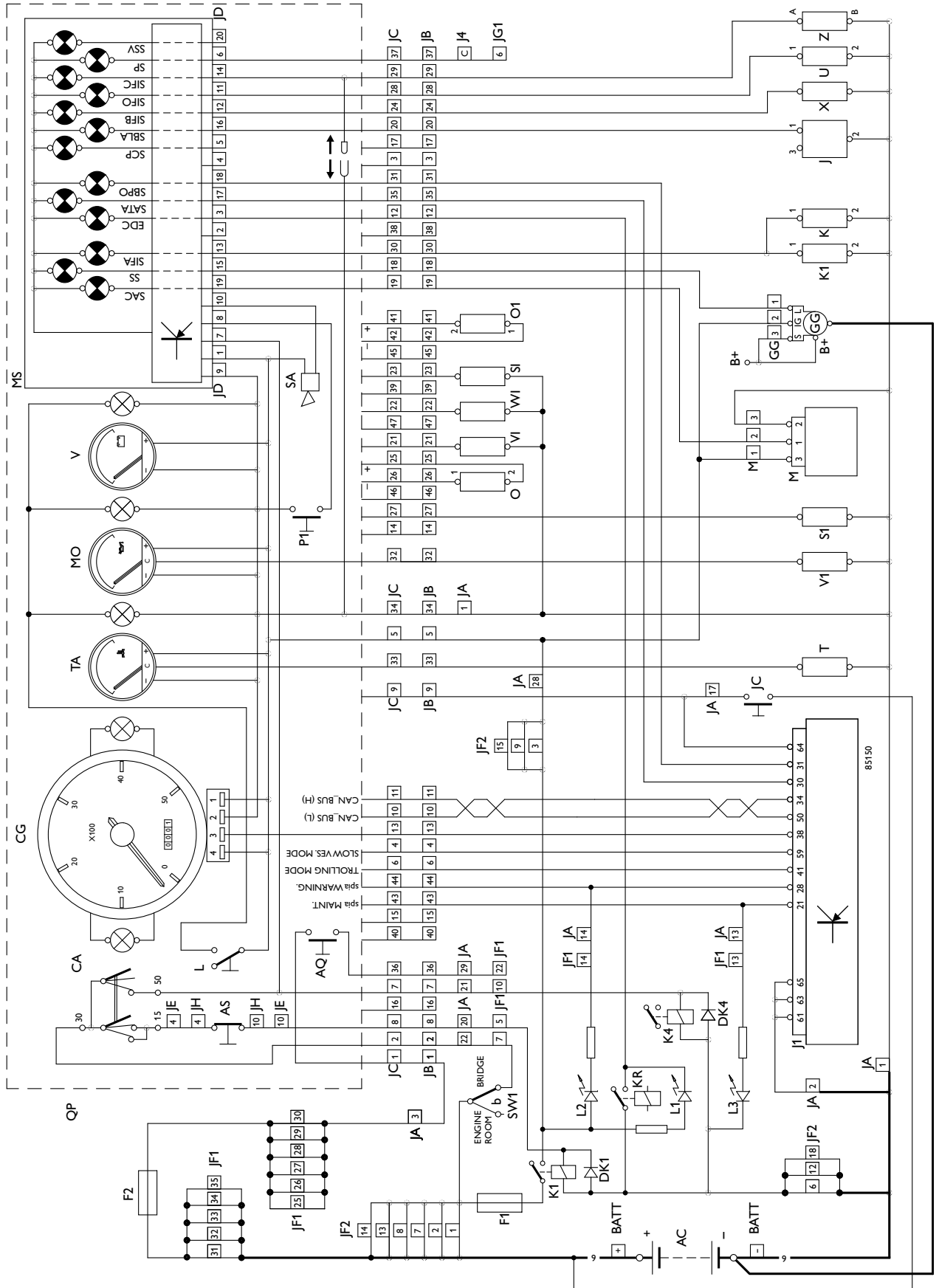

### Secondary analog instrument panel

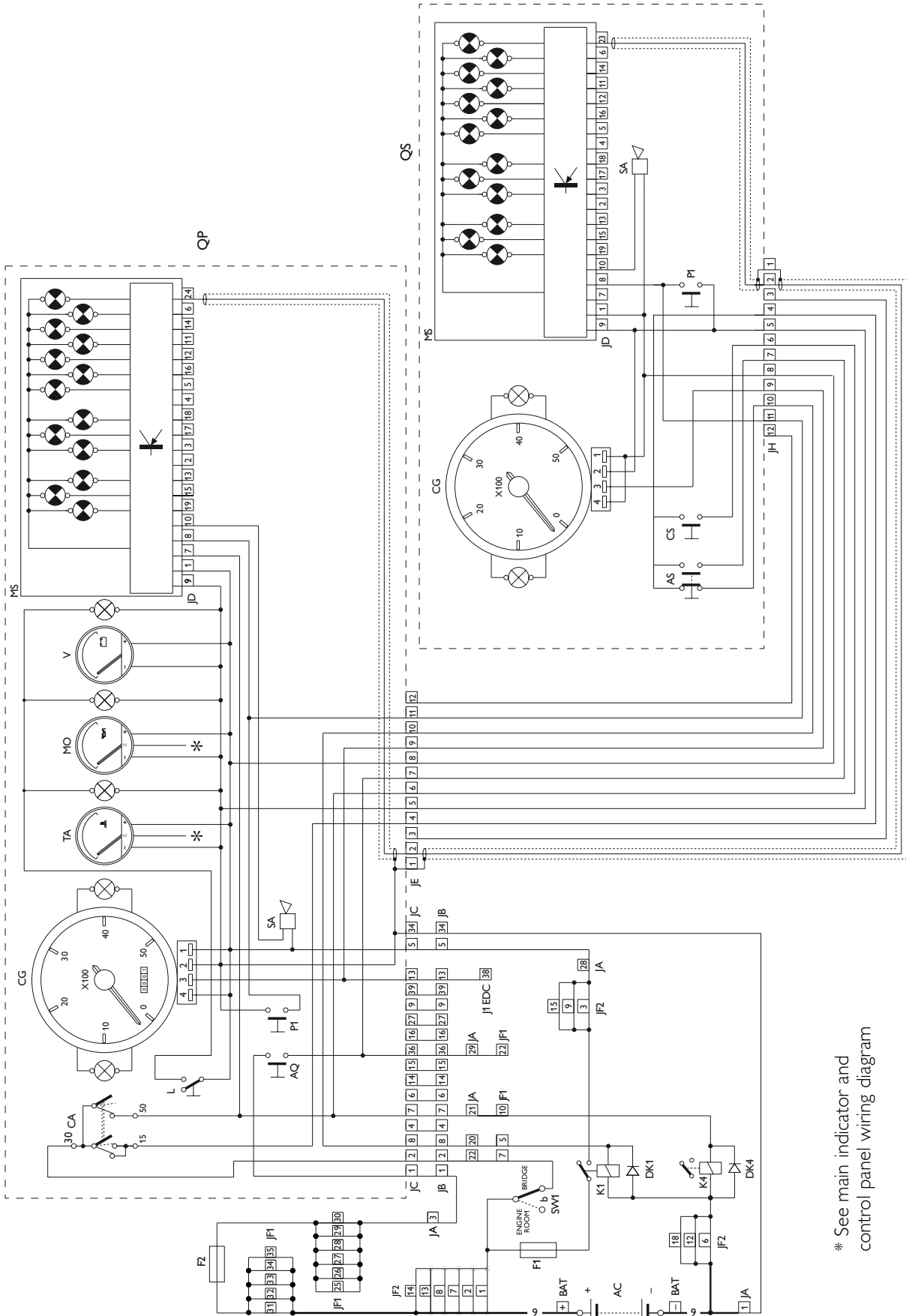

\* See main indicator and control panel wiring diagram



### Wiring of a specific personalised instrument board

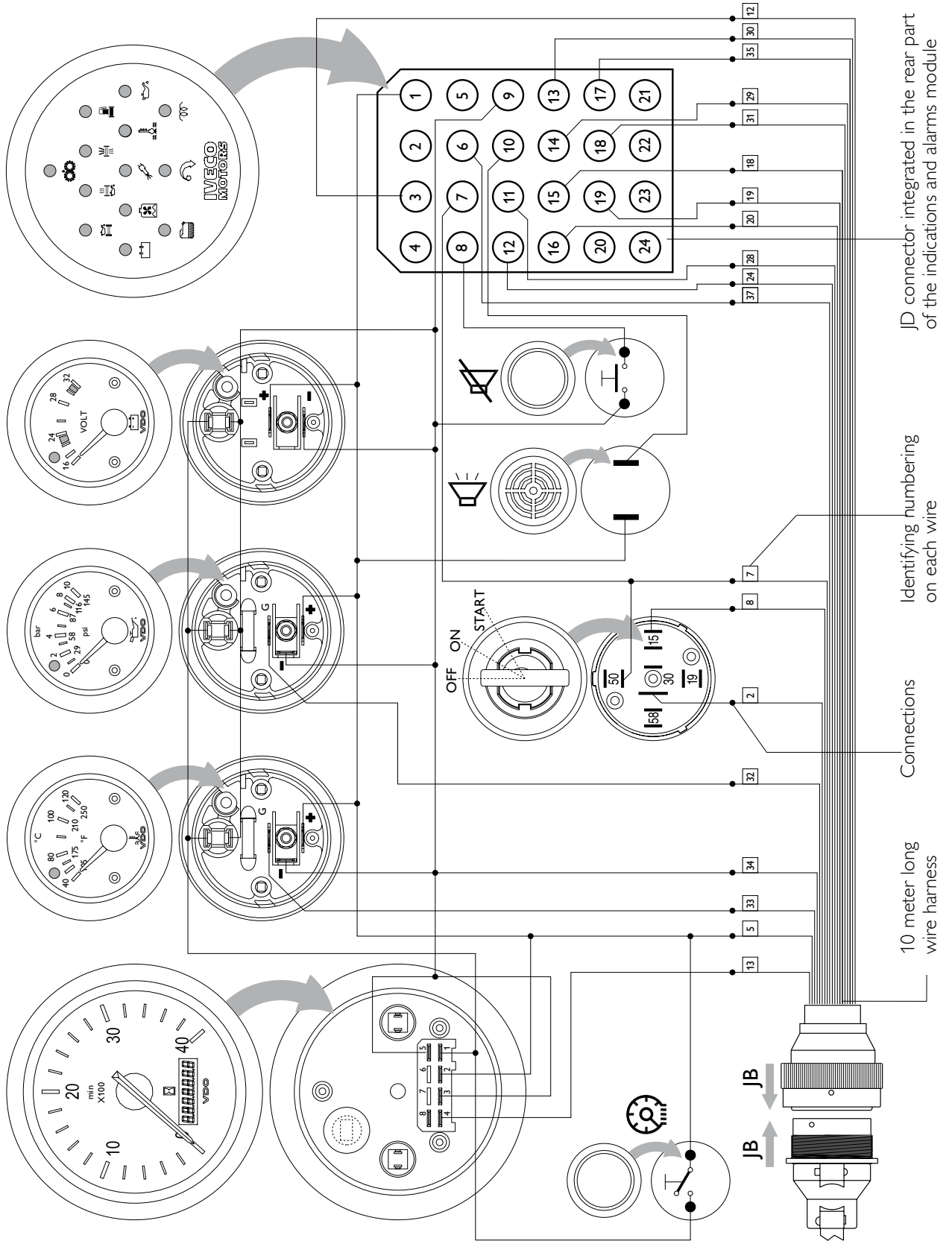

### Wiring of the double personalised instrument board (main and secondary board)

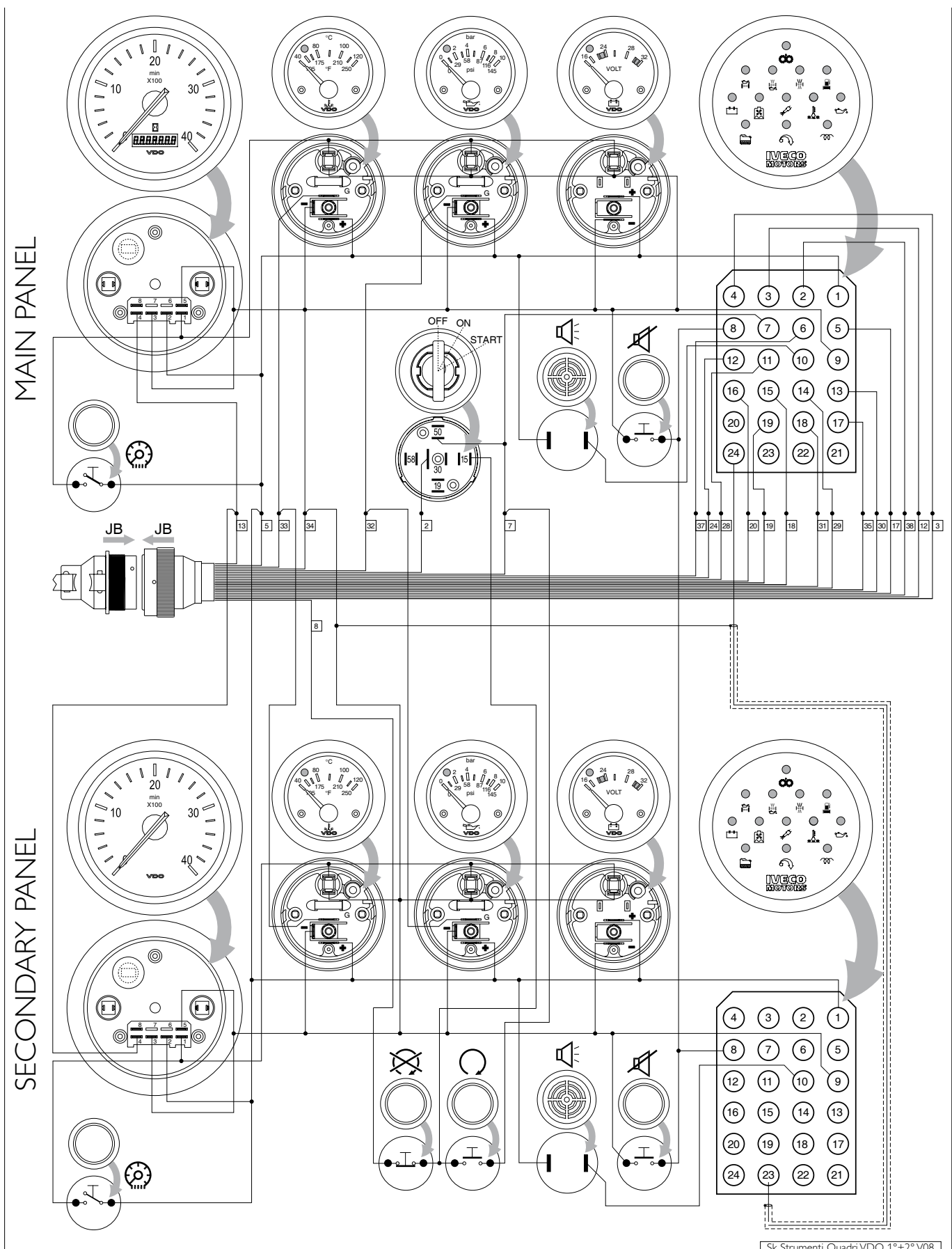

### Supplementary services battery recharge

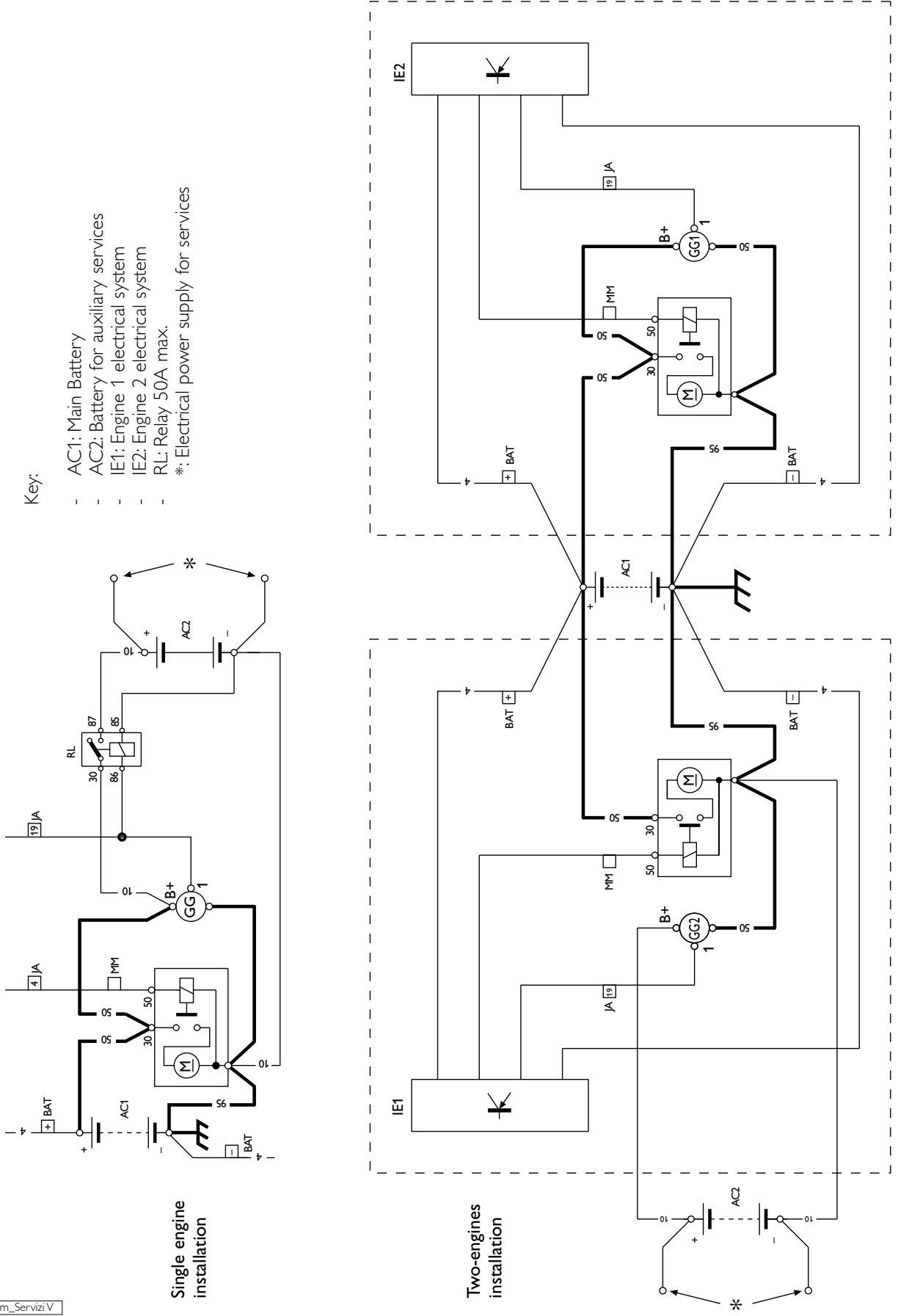



**21. APPENDIX**

	Page
LUBRICATING OIL TRANSFER MODULE	54
PRE-LUBRICATION MODULE	54

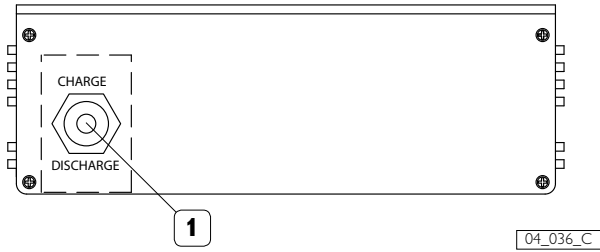
**LUBRICATING OIL TRANSFER MODULE****Figure 1**

1. Oil discharge control.

Lubricating oil exhaust operations are simplified by the presence of an electrical control system connected to the JG connector of the interface wiring harness. Manual control for exhaust operations is positioned on the front panel unit. For safety reasons, control is enabled only with the key switch in the "OFF" position.

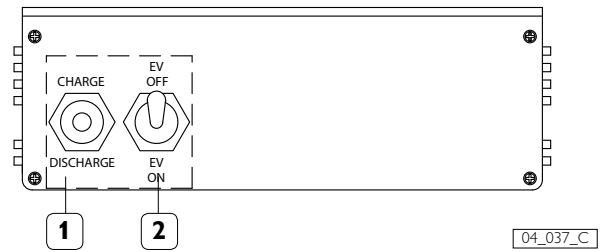
**PRE-LUBRICATION MODULE****Figure 2**

1. Not used - 2. Not used.

The module (on request) is connected to the JG1 connector of the interface wiring harness.

The task of pre-lubricating the engine's internal components is managed and controlled by the electronic circuit of the module when the key switch is placed in "ON" position.



**IVECO  
MOTORS**



IVECO S.p.A.  
PowerTrain

Viale Dell'Industria, 15/17  
20010 Pregnana Milanese - MI - (Italy)

Tel. +39 02 93.51.01 - Fax +39 02 93.59.00.29

[www.ivecomotors.com](http://www.ivecomotors.com)